



HOTSTART®

Circulating Heating System

Installation & Operation Manual



HOTSTART®

**HOTSTART, Inc.
P.O. Box 11245
Spokane WA 99211-0245**

Customer Support: (509) 536-8660

NOTICE

When ordering replacement parts for your heating system, always reference the heating system's Model Number and Serial Number.



Important Safety Information

WARNING

All electrical work must be done by qualified personnel in accordance with the national electrical code and applicable state and local codes.

System can start automatically and without warning. Before wiring, servicing, or cleaning the system turn off the power and install a lockout on the heater circuits at the service panel.

CAUTION

Installers and operators of this equipment must be thoroughly familiar with the instructions in this manual before commencing work.

Use proper lifting equipment and rigging to move this equipment. Create a plan before attempting to move.

Hot surfaces: avoid contact with the system while it is in service—some surfaces may stay hot *even if the system is not energized*. Use common sense when performing any maintenance on this equipment.

Rotating equipment: system can start automatically and without warning—avoid contact unless a lockout at the service panel has been installed.



HOTSTART, Inc.

EAST 5723 ALKI AVENUE • P.O. BOX 11245
SPOKANE, WASHINGTON • 99211-0245 • USA
Phone: (509) 534-6171 • Fax: (509) 534-4216

Note

This manual was prepared to assist you with the installation, operation, and maintenance of the HOTSTART circulating heating system. We encourage you to use this manual and the attached documentation in the appendix as your primary source of information about the heating system. For additional information, contact:

HOTSTART, Inc.
P.O. Box 11245
Spokane, WA 99211-0245
Telephone: (509) 536-8660
Fax: (509) 534-4216

Please check the back of this manual for documents that include your system drawings, wiring diagrams and replacement parts.

Identifying Your System

The HOTSTART heating system is a compact heating system designed for use in marine propulsion, diesel-powered generator sets, gas compression, or any large-engine applications. The system is pre-wired, pre-plumbed, and assembled on a steel plate and mounting channel. Each heating system has an identification plate with the part number and serial number on it. Please reference those numbers when ordering replacement parts.

NOTE: When ordering replacement parts, be sure to reference your heating system's model and serial numbers found on the identification plate.

HOTSTART. 	SPOKANE, WA U.S.A.	<small>REF. SERIAL NUMBER WHEN ORDERING REPLACEMENT PARTS</small>
MODEL _____		
VOLTS _____ HERTZ _____		
AMPS. _____ PHASE _____		
CONTROL CIRCUIT VOLTS _____		
CONTROL CIRCUIT AMPS. _____ MAX		
SERIAL NUMBER _____		<small>U.S. PATENTS 4,245,593, 4,249,491 CAN. PATENTS 1,087,473, 1,082,541</small>
CAUTION OPEN CIRCUITS BEFORE WORKING ON THIS EQUIPMENT OR REMOVING COVERS. KEEP COVERS TIGHTLY CLOSED WHILE CIRCUITS ARE ALIVE.		
ATTENTION DE' BRANCHEZ LE CIRCUIT AVANT DE' COUVRIR NE DE COUVREZPASTANT QUE LE CIRCUIT EST ACTIF		

Example label—actual label may vary slightly from model to model, but the general layout is the same.

Warranty Information

The warranty below has been drafted to comply with the Federal Law applicable to products manufactured after December 31, 1976. This warranty gives you specific legal rights, and you may also have other rights which vary from state to state.

HOTSTART products are warranted against defects in workmanship and materials. No other express warranty, written or oral, applies. No person is authorized to give any other warranty or assume any liability except by written statement from an officer of HOTSTART, Inc.

The warranty extends for twelve months from date of shipment from factory or authorized distributor.

Products must be installed and maintained in accordance with HOTSTART, Inc. instructions. Users are responsible for the suitability of the products to their application. There is no warranty against damage resulting from corrosion, misapplication, improper specification or other operating conditions beyond our control. Claims against carriers for damage in transit must be filed by the buyer.

Unauthorized alterations to factory supplied equipment voids this warranty. Consult the factory if modifications are required.

Absolutely no material can be returned to HOTSTART, Inc. without prior factory authorization.

Upon factory authorization, return the defective part or product, freight prepaid, to: HOTSTART, Inc., 5723 E. Alki, Spokane, WA 99212. Telephone (509) 534-6171; FAX (509) 534-4216.

Defective items will be repaired or replaced, at our option, at no charge. Such repair or replacements is the exclusive right of HOTSTART, Inc. HOTSTART, Inc. is not liable for labor costs incurred in removal, reinstallation, or unauthorized repair of the product or for damage of any type whatsoever including incidental or consequential damage. Some states do not allow the exclusion or limitation of incidental or consequential damages, so the preceding limitation or exclusion may not apply to you.

HOTSTART, INC.

Table of Contents

IDENTIFYING YOUR SYSTEM	<i>i</i>
WARRANTY INFORMATION	<i>ii</i>
INSTALLATION AND START-UP INSTRUCTIONS	1-1
Mounting.....	1-1
Plumbing – Coolant Systems	1-2
Coolant Supply Line	1-2
Coolant Discharge Line	1-2
Coolant System Diagram.....	1-3
Coolant Pressure Relief Valve	1-4
Plumbing – Oil Systems	1-5
Lube Oil Supply Line.....	1-5
Lube Oil Supply Line Sizing Chart	1-6
Lube Oil Discharge Line.....	1-7
Oil System Diagram	1-7
SYSTEM CONTROLS	1-9
System Components	1-9
Main Power Supply.....	1-9
Pressure Switch Remote Control	1-10
24 VDC Remote Control	1-11
PLC Control	1-11
Optional 24 VDC Relay (Mechanical Systems)	1-11
Heating System Start-Up PLC Controlled	1-12
Heating System Start-Up Mechanical Control	1-13

SYSTEM OPERATION.....	2-1
PLC Control Flow Detection.....	2-1
Mechanical System Flow Detection.....	2-1
Coolant Inlet/Outlet Process	2-2
Oil Inlet/Outlet Process	2-3
Operation (PLC Control).....	2-4
Text Display.....	2-5
Use of the Text Display	2-5
On/Off.....	2-5
System Temperatures.....	2-6
Set Temperature	2-7
Operation (Mechanical Control)	2-8
MAINTENANCE & TROUBLESHOOTING	3-1
System Maintenance	3-1
Control Box.....	3-1
Plumbing Connections.....	3-1
Electrical Connections	3-2
System Mounting.....	3-2
Magnetic Contactors	3-2
Heating Tanks	3-3
Pump and Motor Assemblies	3-4
Motors	3-4
Pumps	3-5
Flow Rates	3-6
Flow Detection Switch (Mechanical Controlled Systems).....	3-7
MPS Reset Buttons	3-8
Heating Element Replacement & Element Thermocouple Replacement.....	3-9
Re-assembly of Heating Element and Tank	3-10
PLC Controlled Systems (Tank Thermocouple Replacement)	3-11
PLC Control Troubleshooting.....	3-12
Mechanical System Troubleshooting	3-15

Installation and Start-Up Instructions

WARNING

Hazardous Voltage:

Installation and maintenance should be performed only by personnel who are technically competent and authorized to do so. National, state, and local electrical and safety codes must be observed. Proper grounding is required to avoid electrical shock hazard.

Mounting and Plumbing

Mounting

CAUTION

Heavy equipment:

Proper rigging and safety equipment must be used to move this equipment—weight is not centered. Plan ahead before attempting to move this equipment.

Mount the heating system as low and as close to the suction port on the engine as possible. If the system is a dual fluid system (coolant and oil), it should be mounted such that both suction line lengths are minimized with priority given to the oil suction line. The use of elbows in the suction line(s) should be reduced or eliminated if possible.

Note: Clearance is required for heating element removal—verify that sufficient clearance exists before mounting heating system.

NOTICE

To avoid vibration related problems, properly vibration-isolate the heating system from the engine.

Plumbing - Coolant Systems

Coolant Supply Line

Connect a 1.25 inch (32mm) I.D. or larger coolant supply line from the main coolant drain of the engine to the inlet of the heating system as shown on the following page.

Coolant Discharge Line

Connect a 1 inch (25mm) or larger coolant return line from the outlet of the heating system to the highest possible location on the engine coolant system opposite the main coolant drain (see diagram on following page). This connection enables heated coolant to be circulated through the entire engine. Additional lines may be needed to heat auxiliary components.

Fill cooling system following engine manufacturer's recommendations. Bleed air from the heating system and top-off coolant.

<i>NOTICE</i>

Do not reduce the inlet line.

- Reducing the inlet line will result in pump damage

Position the heating tank so that it is completely full of coolant while in operation.

- Failure to completely fill the heating tank with coolant will result in element damage.

Prime the pump and fill the suction line before starting the system.

- Pump is not self-priming. Liquid must be present in the pump before startup. Trapped air inside the pump will cause pump and seal damage.

Follow engine manufacturer's recommendations for coolant mixture.

- HOTSTART recommends using pre-mixed coolant. **Do not** use tap water to mix with coolant—element damage will occur.

Coolant System Diagram

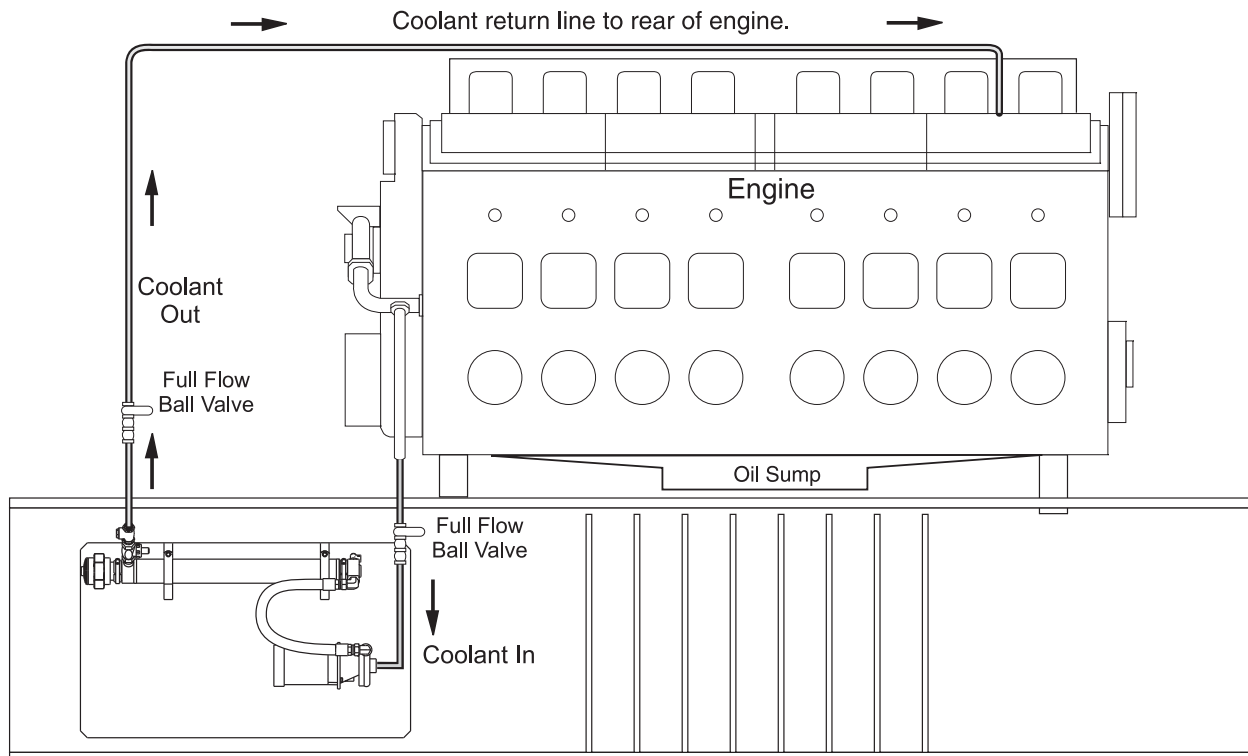

NOTE: Upon completion of coolant line installation, top-off the coolant level to compensate for the coolant used to fill the lines and heating tank. The system should be configured with user supplied full flow ball valves in the coolant lines allowing maintenance on the heating system without draining the engine coolant.



Pressure and steam hazard: power must be turned off and locked out at the main service panel when the ball valves are in the closed position. Failure to do so may result in the release of pressurized steam.

Open ball valves before operating system.

Coolant Pressure Relief Valve

The system is equipped with a pressure relief valve that is pre-set to relieve at 90 psi. Attach pipe that is sized to the outlet of the pressure relief valve and direct it toward a safe area. When operating properly releases are rare, but it is recommended that a bucket or other catch-basin be located under the release pipe to avoid damage to surrounding items if a release occurs.

⚠ WARNING

**Pressurized steam hazard:
Outlet must be plumbed to a safe
place in case an over-pressure
release of hot coolant occurs.**



**Coolant Pressure Relief Valve
P/N: PRP203018-000**

Plumbing - Oil Systems

Lube Oil Supply Line

Connect an oil supply line from the sump of the engine to the suction side of the heating system.

NOTICE

If the heating system is mounted above the oil level, a full flow check valve must be installed in the suction port at or near the sump to avoid losing the prime of the pump during system shutdown.

The sizing of the suction line is critical to the proper operation of the heating system. The pump requires a maximum of 7.5 psi (15 inHg) suction lift. Several factors affect the suction lift and must be addressed. These include: the height above or below the oil that the pump is located, the viscosity of the oil, the size and configuration of the suction line, and the altitude of the system (barometric pressure).

The suction line size can be determined using the following calculations (see chart on following page):

- 1 - The flow rate of the pump is listed in the pump and motor assemblies section of this manual. Determine the flow rate of the system using these values. The table on the next page displays friction losses for smooth pipes at specified flow rates and lengths. Use this table to determine the frictional losses in the intended suction line.
- 2 - Determine the height differential between the pump and the level of oil in the sump. Multiply the number of feet by 0.38—this number will be negative if the pump is below the oil level and positive if the pump is above the oil level.
- 3 - Establish the altitude above sea level where the system will be operating. For every 1000 feet above sea level, 0.5 psi will need to be added. For example: if the system will be operating at 4000 feet above sea level, 2 psi of suction lift will need to be added.

Add the three numbers together to determine the suction lift for the proposed setup. **If the number is greater than 7.5, do not use the setup**—either increase the diameter of the suction line, move the heating system closer to the sump, or lower the system to decrease the suction lift as necessary to achieve a number less than or equal to 7.5 psi.

NOTE: *Your system should be configured with user supplied, non-restrictive ball valves in the oil lines allowing maintenance on the heating system without draining the engine oil.*

Oil Pump Suction Line Sizing Chart

(SAE 40 Motor Oil at 80° - 100°F)

Line Size ID	2 – 3 GPM Friction Losses (psi)						7 GPM Friction Losses (psi)					
	Length (feet)						Length (feet)					
	5	6	7	8	9	10	5	6	7	8	9	10
0.75 in	4.0	4.8	5.5	6.3	N/A	N/A	N/A	N/A	N/A	N/A	N/A	N/A
1 in	1.5	1.8	2.2	2.5	2.8	3.1	3.1	3.7	4.3	4.9	5.5	6.2
1.25 in	0.5	0.6	0.7	0.8	1.0	1.1	1.0	1.2	1.4	1.6	1.8	2.0
1.5 in	-	-	-	-	-	-	0.6	0.7	0.8	0.9	1.0	1.1

Line Size ID	10 GPM Friction Losses (psi)						20 GPM Friction Losses (psi)					
	Length (feet)						Length (feet)					
	5	6	7	8	9	10	5	6	7	8	9	10
1 in	4.4	5.3	6.2	7.0	N/A	N/A	N/A	N/A	N/A	N/A	N/A	N/A
1.25 in	1.5	1.8	2.1	2.4	2.7	3.0	2.9	3.4	4.0	4.6	5.1	5.7
1.5 in	0.8	1.0	1.1	1.3	1.4	1.6	1.6	1.9	2.2	2.5	2.9	3.2
2 in	-	-	-	-	-	-	0.6	0.7	0.8	0.9	1.0	1.1

Line Size ID	25 GPM Friction Losses (psi)						30 GPM Friction Losses (psi)					
	Length (feet)						Length (feet)					
	5	6	7	8	9	10	5	6	7	8	9	10
1.25 in	3.6	4.3	5.1	5.8	6.5	7.2	4.4	5.3	6.2	7.0	N/A	N/A
1.5 in	2.0	2.4	2.8	3.2	3.6	4.0	2.3	2.7	3.2	3.7	4.1	4.6
2 in	0.7	0.9	1.0	1.2	1.3	1.5	0.9	1.1	1.2	1.4	1.6	1.8
2.5 in	-	-	-	-	-	-	0.4	0.5	0.6	0.7	0.8	0.9

Lube Oil Discharge Line

Size the discharge line per the outlet of the heating system. There are two options for the discharge line of the HOTSTART oil heating system. The heated oil can be returned to the opposite end of the oil sump, or engine pre-lubing can be achieved by installing a tee in the discharge line along with a solenoid valve or manual three-way valve.

Oil System Diagram

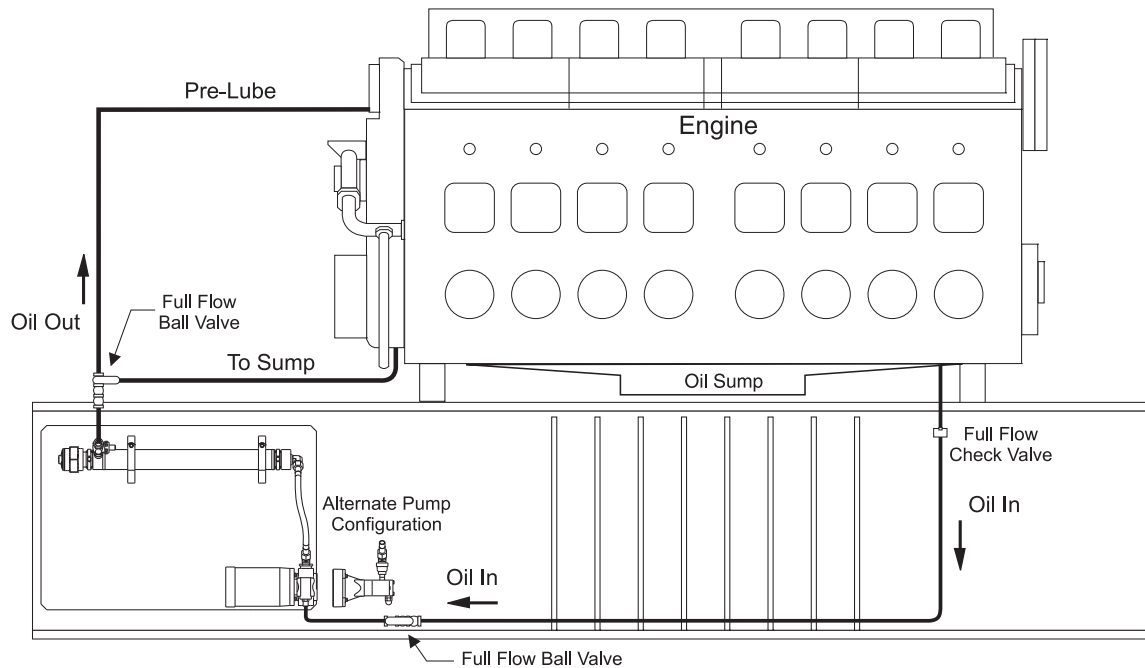

NOTICE

See engine manufacturer requirements for pre-lubing. HOTSTART does not specify flow rates or pressure for pre-lube systems.

- *Continuous pre-lube can cause oil to leak into the cylinders and cause engine damage on startup.*

Lube oil pump must be primed prior to startup.

- *Failure to prime the pump will result in pump and/or seal damage.*

Open ball valves prior to operating system

- *Failure to open valves will damage pump*

Oil Pressure Relief Valve

The oil pump has an internal pressure relief valve that is pre-set to relieve into the inlet. No adjustments should be necessary.

System Controls

System Components

The control box contains the electrical control components for the heating system. Following is an overview of operation for the standard parts located on the system, including:

- Main Power Supply
- 24 VDC PLC Remote Control
- 24 VDC Relay Control
- Pressure Switch Remote Control

Parts in the control box may vary, depending on the particular system configuration purchased.

Main Power Supply

Connect the specified power (+ or – 10% of the rated voltage) to the terminal blocks located in the main control box. For 3-phase applications, the terminal blocks are labeled L1, L2, and L3. For single phase applications, use the terminal blocks labeled L1 and L3.

The main power ground wire must be connected to the ground lug on the electrical panel located inside the electrical box.

The main power supply operates the heating elements and the circulating pumps. A transformer, used to operate the control circuit, drops the main supply voltage to 120V. The transformer and control circuits are overload protected with fuses and/or a circuit breaker.



⚠ WARNING

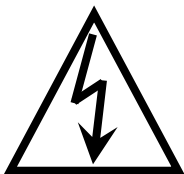

All wiring shall be done by qualified personnel in accordance with national, state, and local codes. Each system shall be grounded in accordance with the National Electrical Code. Failure to properly ground the system may result in electric shock.

Hazardous Voltage: A lockout must be used at the main service panel when work is being done inside the control box to avoid electrocution.

Pressure Switch Remote Control (optional)

Shown below are the pressure switches used on the different heating systems. These switches must be connected to the pressure side of the engine oil—not the suction side. When oil pressure drops due to engine shut down, the switch turns on the heating system; when oil pressure rises from engine start-up, the switch turns off the heating system.

NOTE: *Care should be taken not to connect this line too close to the discharge of the oil heating system or the pressure created by the heating system's oil pump could shut the heating system down.*

NOTE: *On the explosion resistant (ER model) heating systems, the inlet fitting of the pressure switch should never be turned when connecting the oil line. Hold the hex nut fitting firmly when attaching the oil line.*



**Explosion Resistant
Pressure Switch
P/N: PRP224078-000**



**Watertight Pressure Switch
P/N: PRP224008-000**

24 VDC Remote Control

PLC Controlled Systems

For remote control operation on standard PLC controlled systems, connect a 24VDC normally closed signal (24VDC supplied when engine is running) from the engine to the PLC. Reference the control box wiring diagram in the back of the manual for connection locations on the input side of the PLC. The PLC will shut off the heater when 24 volts is applied and turn the heater back on when the voltage is removed.

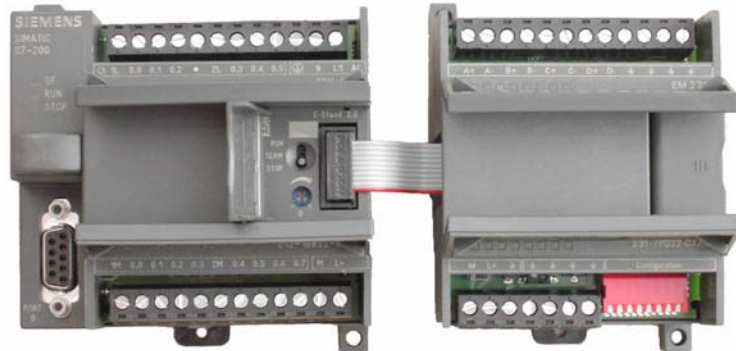

CPU 222 P/N: PRP221035-002
CPU 224 P/N: PRP221035-001

Thermocouple Module
P/N: PRP221042-000

Mechanically Controlled Systems

Optional 24VDC Relay Control

For remote control operation, connect a 24VDC signal from the engine to the 24VDC relay coil. The relay will shut off the heater when 24 volts is applied and turn the heater back on when the voltage is removed. Reference the control box wiring diagram in the back of the manual for connection locations.



Mechanical 24V Relay
P/N: PRP224047-001

Heating System Start-Up—PLC Controlled

Step 1 Check and tighten all electrical and plumbing connections.

Step 2 **Check for proper rotation of the motor** by quickly turning the system on and then back off again while watching the motor shaft or fan. Single phase systems are pre-wired to rotate the correct direction. For three phase systems: if the pump is not rotating the correct direction; switch any two electrical leads at the power-in block. If the system is a combination system (heats both coolant and oil), the two motors are synchronized to turn the same direction; if one motor is turning the wrong direction, the other will do the same. Switching the leads at the power-in block will change both motors.

NOTICE

*DO NOT RUN MOTOR/PUMP ASSEMBLY DRY
MORE THAN A FEW SECONDS.*

- *Running a pump that is not completely filled with liquid will cause damage to the seal*

Step 3 **The pumps MUST BE PRIMED.** It is important to remove all trapped air in the suction side of the system. If necessary, disconnect a fitting near the pump on the suction line and fill with fluid. **Bleed all trapped air from the pump prior to energizing the system.**

CAUTION

Pressurized steam hazard:

Open ball valves before energizing the system

Step 4 Energize the heating system by switching the power switch to the ON position or pressing the ON/OFF button(s) on systems equipped with a text display. You should be able to hear fluid moving through the lines. If not, loosen a fitting on the discharge line of the pump to verify flow.

Step 5 The heating system pump will run for three minutes while initializing the PLC before the heating element will energize. If the system does not detect flow after the heating element energizes, it will turn the heating element off and indicate an error by either flashing the control box pilot light, or if your system is equipped with a Text Display, this error will be indicated on it. To clear this error, turn the system off, **re-prime the pump and check for leaks in the suction line.** Verify that all isolation valves are open and turn the system back on again. The heating system will repeat the initialization process and flow check.

Step 6 Once flow has been established and the heating element has turned on for the first time, the system will run automatically and maintain the fluid at the set temperature. If your system is equipped with a Text Display you can scroll to Temperatures. This will indicate the temperature of the fluid going into and out of the heating tank. If the temperature at the outlet of the tank is a few degrees higher than the temperature at the inlet, this will indicate the element is heating.

Note: *If the fluid is lower than 30°F below set temperature, a Low Temp error will be indicated. This is normal. When the heating element comes on and heats the fluid above this temperature, the error will clear itself.*

Heating System Start-Up—Mechanical Control

(24 VDC Relay or Pressure Switch)

- Step 1** Check and tighten all electrical and plumbing connections.
- Step 2** **Check for proper rotation of the motor** by quickly turning the system on and then back off again while watching the motor shaft or fan. Single phase systems are pre-wired to rotate the correct direction. If the pump is not rotating the correct direction; switch any two electrical leads on three phase systems at the power-in block. If the system is a combination system, the two motors are synchronized to turn the same direction; if one motor is turning the wrong direction, the other will do the same. Switching the leads at the power-in block will change both motors.

NOTICE

DO NOT RUN MOTOR/PUMP ASSEMBLY DRY MORE THAN A FEW SECONDS.

- *Running a pump that is not completely filled with liquid will cause damage to the seal*

- Step 3** **The pumps MUST BE PRIMED.** It is important to remove all trapped air in the suction side of the system. If necessary, disconnect a fitting near the pump on the suction line and fill with fluid. **Bleed all trapped air from the pump prior to energizing the system.**

CAUTION

Pressurized steam hazard:

- **Open ball valves before energizing the system**

- Step 4** Energize the heating system by switching the power switch to the ON position. You should be able to hear fluid moving through the lines. If not, loosen a fitting on the discharge line of the pump to verify flow. If the minimum flow rate is not achieved, or flow restriction in the suction line has occurred, the heating system will automatically shut down approximately 3 minutes after start-up. Turn the system OFF and check plumbing lines for any leaks or restrictions. Repeat steps 2, 3, and 4.

NOTE: *On initial start-up, it may take several attempts to achieve proper flow.*

- Step 5** Once operation is satisfactory; turn the control knob on the system time delay relay to the desired setting. Kim Hotstart recommends a setting of 30 seconds. Turn the heating system off and then back on to activate the new setting.

System Operation

PLC Control—Flow Detection

The PLC based heater uses temperature variation from one end of the tank to the other to verify that there is flow when the heating element is on. Flow direction is not the same in all systems. Reference the flow direction arrows on the heating tank to determine the direction of flow for your system.

When the heater is turned on, the pump starts and the PLC initialization process begins. During initial start up **it is important to verify that the fluid is flowing to prevent pump damage.** The pump runs for three minutes before the heating element is allowed to turn on. This provides time for the pump to circulate the fluid and establish a constant temperature in the fluid. The PLC then calibrates the thermocouples as part of the initialization process.

Note: To verify that there is flow; loosen a fitting on the discharge line.

At the end of the three minutes the heating element will turn on if the temperature of the fluid is lower than the set operating temperature. If the fluid is flowing correctly and the element is on, the PLC will determine a temperature variation from one end of the tank to the other. The heating process will continue.

If it is not flowing correctly then the PLC will indicate an error by flashing the pilot light on the front of the control box or indicate an error on the text display. It will also shut off the heating element to prevent damage to it. **If there is a flow error it is important to determine the cause and correct it to prevent pump damage. Do not leave the pump running if there is a flow error.**

Following a flow error correction (i.e. - valves closed, hose kinked, pump not primed), turn the heater off and then back on. This will reset the PLC and restart the initialization process.

Mechanical System—Flow Detection

Following the inlet and circulation through the heating tank, the fluid passes through a flow detection switch, which immediately shuts off the heating element anytime there is an interruption or loss of flow, and activates the time delay relay located inside the control box. The pump continues to circulate the fluid to restore flow.

If proper flow is not reestablished, the time delay relay shuts down the entire heating system according to a preset time. The time delay relay is adjustable from 0 - 180 seconds. Upon an initial system start-up, the time delay relay should be adjusted to the maximum of 180 seconds. Once flow is achieved, Kim Hotstart recommends a setting of 30 seconds. To activate a new setting, the heating system must be turned off and then turned back on.

This automatic system shut down feature protects the heating element and other major components from damage. Upon a system shut down, the heating system must be reset. To reset, turn the system off and then back on again.

Coolant Inlet/Outlet Process

Upon energizing the system, engine coolant, taken from the coolant drain area in the lower section of the engine, is circulated through the heating tank via a centrifugal pump.

Coolant then passes through a check valve or optional solenoid valve, which limits coolant backflow while the engine is operating. Finally, heated coolant is returned to the back top of the engine at its optimum starting temperature.

The heating system is designed to run continuously while the engine is not running. The heating element will cycle on and off with the system thermostat to maintain the temperature.

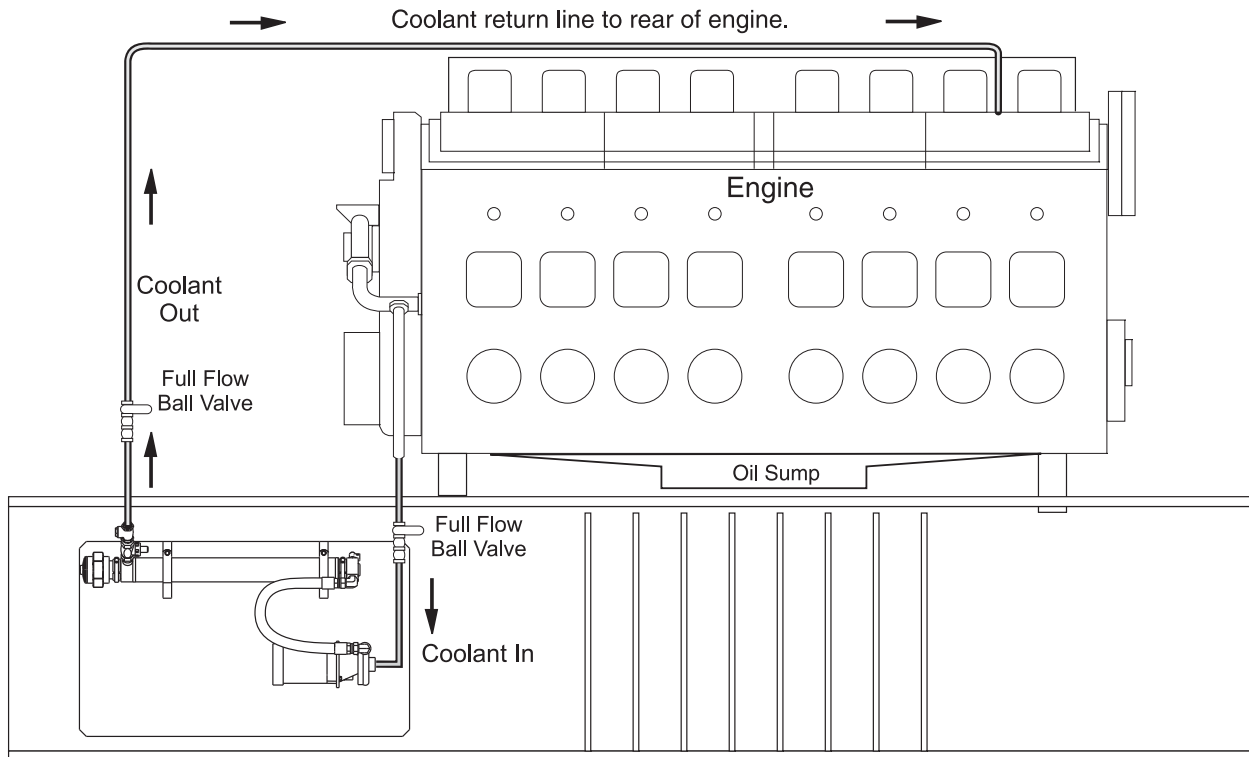

Oil Inlet/Outlet Process

When the system is energized, a positive displacement rotary gear pump takes oil from the engine sump and forces it through the heating tank and into the return line.

The return line can be routed back to the sump, or can be sent to the top of the engine for pre-lube and post-lube purposes.

NOTICE

See engine manufacturer requirements for pre-lubing. HOTSTART does not specify flow rates or pressure for pre-lube systems.

Continual pre-lubing can cause permanent engine damage. Consult the engine manufacturer for proper pre-lube techniques.

The heating system is designed to run continuously while the engine is not running. The heating element will cycle on and off with the system thermostat to maintain the temperature.

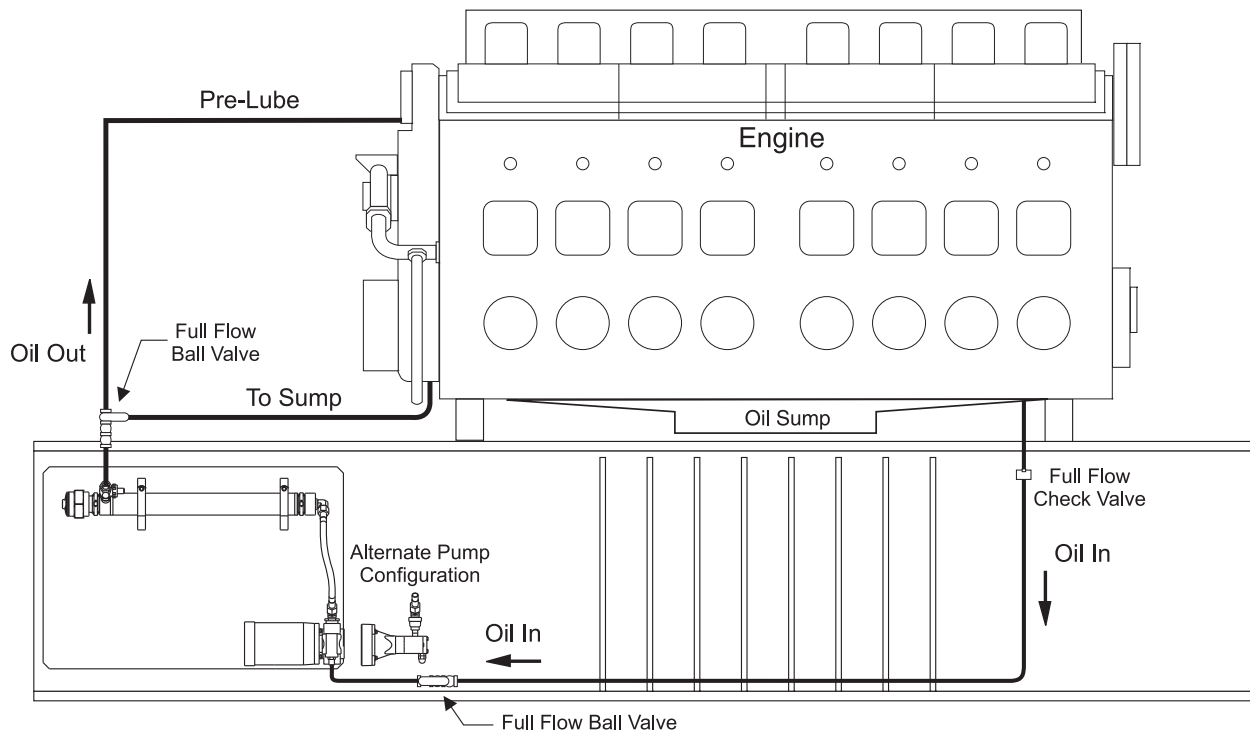

Operation (PLC Control)

PLC stands for Programmable Logic Controller. It has a program written and installed into its permanent memory that uses inputs and outputs to control the heating system and provides signaling and diagnostics of failures.

The system inputs are from the switches or a text display on the front of the control box, a remote start/stop signal, motor protective switches, and temperatures from thermocouples in the heating tank. Its outputs include the pump motors, heating elements and pilot lights or text display.

The LED's on the PLC indicate which inputs and outputs are functioning at any given time, as well as error signaling.

A new program can be installed in the PLC by using an E-prom chip that plugs into the top of the PLC. By cycling power off and on after plugging the e-prom chip in, the program is replaced.

Text Display

For systems using the Text Display:

If the system is equipped with a text display it serves several purposes:

On/off control for the heating system

System status and system temperatures.

If an error occurs it lists the error on the display.

The text display also allows the user to set the operating temperature.

Use of the Text Display



**Text Display
P/N: PRP221044-000**

The photos shown are for a combination system, if your system is a single fluid system, only the appropriate information is shown.

On/Off

If the system is equipped with a text display the ON / OFF keys toggle from ON to OFF and control the coolant and oil heating systems independently. When an ON button is pushed the text display shows the system status as "ON". When it is pushed again it shows the status as "OFF".

Pushing the arrow keys scrolls from one window to the next. You can scroll either up or down to get to the desired window.

System Temperatures

To read the system temperatures simply scroll to the window displaying the temperatures. The two temperatures displayed are the inlet temperature and the outlet temperature. The inlet temperature is the temperature at the inlet of the heating tank. This is the temperature of the fluid as it comes out of the engine. This is the minimum temperature of the engine and the temperature that cycles the heating element. The outlet temperature is the temperature at the outlet end of the heating tank and is used to determine that there is flow in the heating tank. When the heating element is on and there is flow through the tank the outlet temperature will be a few degrees higher than the inlet temperature.

```
COOLANT IN TEMP  0.0  
COOLANT OUT TMP  0.0
```

**Text Display
Coolant Temperature**

```
OIL INLET TEMP  0.0  
OIL OUTLET TMP  0.0
```

**Text Display
Oil Temperature**

Error Codes

The window that lists “ERROR” will show “NO ERRORS REPORTED” if there are no errors. If the system detects an error it will display it on the second line of that window. To clear the error after making appropriate repairs or changes, turn the system off and back on again. If the error is still displayed, it has not been fixed. Some errors will not occur until the heating element has turned on. The pump will run for three minutes before the heating element will turn on. The heating element will not turn on for the first time until the inlet temperature is 10 degrees below the set temperature. Error codes are listed on the next page. The three previous error codes are listed at the top right of this window. The most recent error is on the left. Some errors will clear themselves. After they have cleared they will only show on the top line as previous errors.

```
C  ERROR:  0  0  0  
NO ERRORS REPORTED
```

Text Display Coolant Errors

```
C  ERROR:  3  0  0  
C  LOW TEMPERATURE
```

```
O  ERROR:  0  0  0  
NO ERRORS REPORTED
```

Text Display Oil Errors

```
O  ERROR:  3  0  0  
O  LOW TEMPERATURE
```

Set Temperature

The “SET TEMPERATURE” window provides the opportunity for the user to change the operating temperature of the systems. The default is set at 120°F for the coolant system and 100°F for the oil system. To change the pre-set temperature; scroll to the appropriate window and press “ENTER”. There will be a flashing cursor on the far right character in the display. To increase the set temperature; press the up arrow, holding the button down will cause it to continuously increase. To decrease the set temperature, use the down button. When the desired temperature is displayed, press the “ENTER” button again to set the temperature. The temperatures can only be set between the limits shown on the display, coolant 60 – 160°F and oil 80 – 140°F. The set temperature will be stored and used until it is changed again. Turning the system off or powering down will not change these settings.

SET COOLANT TEMP 60 – 160 120.0

SET OIL TEMPERATURE 80 – 140 100.0
--

ERROR CODE TABLE	
Code	Description
1	Heating Element
2	Differential Temp / Lack of Flow
3	Low Temperature
4	Over Temperature
5	Thermocouple Open / Short
6	Motor Protective Switch Tripped
7	Thermocouple Range
8	Thermocouple Module / Power

An error is indicated when the pilot light or PLC flashes the above number of flashes followed by a three second pause. This repeats until the error is resolved and the system is restarted. The text display indicates the code numbers of the three most recent errors. The code numbers are displayed from left to right with the most recent error code number on the left.

Operation (Mechanical Control)

When the heating system is turned on the pump motor runs; continuously circulating warm fluid through the engine and back to the heater.

The heating element is controlled by a thermostat, which cycles on and off to maintain the set temperature. The standard thermostat in coolant systems turns on at 100°F and off at 120°F, while oil systems turn on at 80°F and off at 100°F. Other thermostats are available.

Following the inlet and circulation through the heating tank, the fluid passes through a flow detection switch, which immediately shuts off the heating element anytime there is an interruption or loss of flow and activates the time delay relay (shown below) located inside the control box. The pump continues to circulate the fluid to restore flow.

If proper flow is not reestablished, the time delay relay shuts down the entire heating system according to a preset time which is adjustable from 0 - 180 seconds. Upon an initial system start-up, the time delay relay should be adjusted to the maximum of 180 seconds. Once flow is achieved, HOTSTART recommends a setting of 30 seconds. To activate a new setting, the heating system must be turned off and then turned back on.

This automatic system shut down feature protects the heating element and other major components from damage. The time delay relay and flow detection are discussed in more detail in the *System Components* section of this manual.



Time Delay Relay
P/N: PRP224046-000

Maintenance and Troubleshooting

System Maintenance

The following maintenance procedures are provided to ensure trouble-free operation of your heating system:

- Control Box
- Plumbing Connections
- Electrical Connections and Contacts
- Heating Tanks/Elements
- Pump & Motor Assemblies
- System Mounting

WARNING

HAZARDOUS VOLTAGE:

BEFORE WIRING, SERVICING OR CLEANING THE SYSTEM, TURN OFF THE POWER AND INSTALL A LOCKOUT ON THE HEATER CIRCUITS AT THE SERVICE PANEL. FAILURE TO DO SO COULD ALLOW OTHERS TO TURN ON POWER UNEXPECTEDLY, WHICH MAY CAUSE FATAL ELECTRICAL SHOCK.

Control Box

- Periodically check gaskets for proper seals.
- Check the control box for moisture (if necessary, add desiccant packets).

Plumbing Connections

- Periodically check plumbing connections for leaks and, if necessary, tighten connections. A loose connection on the suction side will cause a loss of flow and cavitation in the pump. It can also pull air into the heating tank and cause an element failure.

Heating Tanks

- At least once per year, clean the interior of the heating tank and the heating element with a wire brush and/or damp cloth. Periodically check the element for sediment build-up around the element loops. Any scaling or build-up will shorten element life. Maintenance and replacement procedures for the heating element are described in System Components of this manual.
- Following lengthy system shut downs, remove the terminal covers of the element assembly as shown in System Components and check for any moisture or condensation. Electric tubular heating elements contain a granular refractory material called magnesium oxide (MGO) to insulate the resistor coil from the outer metal sheath. MGO is hygroscopic, which means it has the ability to absorb moisture from the air. MGO contaminated with moisture reduces the insulating value of the MGO which is measured with an Ohm meter by connecting one leg of the meter to the element and the other leg to ground. It is read as resistance in the meg-Ohms range (1 meg-Ohm = 1 million Ohms = 1M Ohms). Low resistance (less than 1M Ohms) is a transient condition experienced on first heat-up under normal periodic heater usage. Moisture absorption under normal conditions does not affect heater efficiency or life.

The minimum required resistance value is 1.0M Ohms for full power voltage operation. However, heating elements with a moisture barrier sealant such as RTV silicone or epoxy potting will require a minimum value of 5.0M Ohms. Resistance values should be measured with an Ohm meter by applying one lead to the termination and the other to ground. When the heater does not meet the required resistance value, the unit will have to be dried out prior to full power operation.

If the heater has 0.1M Ohms (100K Ohms), or better, but less than 1M Ohms, the heater should be operated at half the rated voltage for 30 minutes to dissipate the accumulated moisture. Disconnect the power after 30 minutes and check the resistance. An alternative to applying voltage is to manually dry the heaters in an oven at 300°F for 4 hours then check its resistance again.

If the resistance is higher than it was originally, repeat the process until the value reaches the minimum requirement of 1M Ohms. The heater can then be operated at full rated voltage.

Pump and Motor Assemblies

WARNING

HAZARDOUS VOLTAGE: Disconnect power and lock out at the service panel before working on the pump or motor.

Motors with automatic thermal protectors will automatically restart when the protector cools.

Explosion resistant motors should only be disassembled by an authorized service station.

Motors

- Two different types of motors are used: one uses sealed bearings and the other ball bearings. Sealed bearings require no maintenance. For ball bearing motors, lubricate fittings according to the following directions:

NOTE: These instructions pertain to Baldor motors only. If the system is equipped with another brand of motor, please consult the manufacturer for proper lubrication. If lubrication instructions are shown on the motor nameplate, they will supersede this general instruction.

Motors are pre-greased with polyurea mineral oil NGLI grade 2 type grease unless otherwise stated on the motor nameplate. Some compatible brands of polyurea mineral base type grease are: Chevron SRI #2, Rykon Premium #2, Shell Oil Dolium R, or Texaco Polystar RB.

Motors are properly lubricated at the time of manufacture. It is not necessary to lubricate at the time of installation unless the motor has been in storage for a period of 12 months or longer.

Re-lubrication

Motors that have re-greasing provisions need to be serviced every year for 1800RPM or less, or every 3 months for all motors rated above 1800RPM. The typical volume of grease is 0.25 in³ (0.14 fluid oz.) for NEMA frame size 140 and 0.50 in³ (0.28 fluid oz.) for NEMA frame size 180.

Pumps

⚠ WARNING

HAZARDOUS VOLTAGE: Disconnect power and lock out at the service before working on the pump or motor.

Motors with automatic thermal protectors will automatically restart when the protector cools.

HOT LIQUID: Contents within the pump or liquid chamber may be hot. Allow system to cool for several hours prior to servicing.

Before opening any liquid chamber (pumping chamber, reservoir, relief valve adjusting cap fitting, etc.). Be sure:

- 1. That any pressure in the chamber has been completely vented through suction or discharge lines or other appropriate openings or connections.**
 - 2. That the system has been locked out at the service panel.**
 - 3. That you know what liquid the pump has been handling and the precautions necessary to safely handle the liquid. Liquid in the pumping chamber and hoses may be hot, make sure that the necessary precautions are taken to avoid serious injury.**
- Pumps - replace seals and gaskets as required. Seal life is very difficult to estimate due to a variety of controlled and uncontrolled conditions the seal operates in. Pump seals by nature will weep some even when new.

The mechanical seal faces cannot be operated in a dry environment. Some liquid must pass between the rotating and stationary face in order to minimize friction and to carry away the heat generated. If this leakage evaporates when reaching the atmosphere, then there is no visible leakage. If it doesn't, leakage in the order of a few drops per day might be the best achievable. Some seal manufacturers rely on high face loading to minimize leakage but at the expense of seal longevity. Others do the opposite, which provides longer life but greater leakage.

Field installation of the seals is not as exact a procedure as is possible when this is done in a factory environment with experienced assemblers. It is possible to experience some minor leakage on field installed seals. Excessive leakage can also be an early indication of seal failure, warning of the need for impending maintenance. Before installing, repairing, or performing maintenance on pumps, read and understand the pump's instructions completely.

Undersized, long or restricted suction plumbing will cause pump seals to leak. This creates an excessive vacuum in the seal chamber which separates the seal faces and allows fluid to leak past the seal.

Flow Rates

Standard Pump Flow Rates and Motor Hp		
Oil Pumps		
Wattage (kW)	GPM	Hp
2.5	2.8	1
6	10	1
9-12	20	2
Coolant Pumps		
9-36	40	3/4

***Note: For 50Hz systems, flow is decreased to 83% of the 60Hz systems shown**

Flow Detection Switch (Mechanical Controlled Systems)

- Inspect the flow detection (flow control) switch periodically for foreign buildup on the shuttle body. To clean the flow detection switch, follow these steps:

- Step 1** Shut OFF fluid supply to the heating system.
- Step 2** Remove the bonnet nut and lift out the entire switch assembly.
- Step 3** Remove accumulated sediment from the switch body with a damp cloth.
- Step 4** Check the switch for proper operation by sliding the shuttle and magnet up over the main shaft as shown below. If the shuttle hangs up or does not slide smoothly, remove the lock ring from the bottom of the switch assembly and slide the shuttle, magnet and spring off.
- Step 5** Remove foreign matter and rough spots from the shaft with denatured alcohol.
- Step 6** Reassemble the switch and check it again for proper operation (reference step 4).

CAUTION: Extreme care must be taken during the next step to avoid electrocution. Do not touch any of the components inside any of the electrical enclosures during this test.

- Step 7** To test operation of the switch assembly, turn ON the main power. When the magnet on the shuttle is slid up the shaft, the magnetic contactor that operates the heating element should close.

CAUTION: When testing the flow switch, do not operate the heating system longer than 5 seconds or damage to the heating element may occur.

- Step 8** Once the switch assembly is working properly, reassemble the flow switch and set the time delay relay to the desired setting. The recommended setting is 30 seconds.



Explosion resistant
P/N: PRP224033-200
Watertight P/N:
PRP224033-000

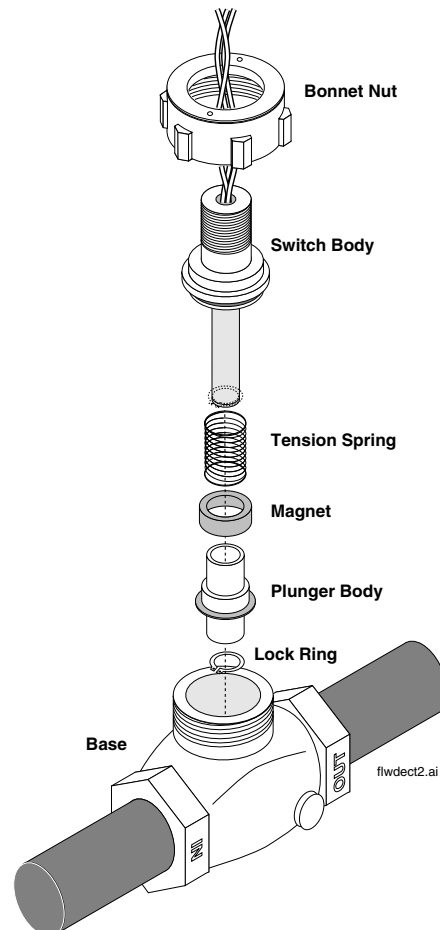

MPS Reset Buttons

Both the NEMA 12 and the Explosion Resistant model control boxes contain motor protector switches to safeguard against overloads and short-circuits.

On an Explosion Resistant model, press the RESET button on the control box's lid to reset the motor protector switch (inside the control box).

On a NEMA 12 model, it is necessary that you open the control box to reset the motor protector switch:

1. Check the position of the green START and the red STOP RESET buttons on the motor protector switch. In normal operation the red STOP RESET button is up and the green START button is down.

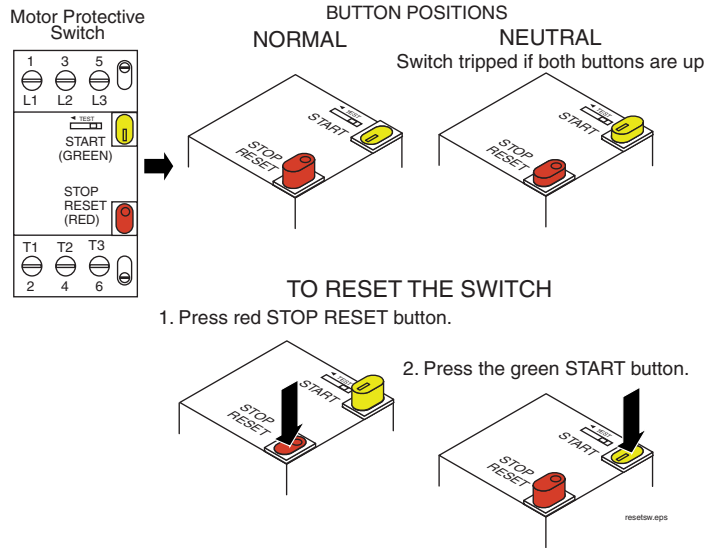

2. If both buttons are up, the switch has been tripped. To reset, first press the red STOP RESET button and then press the green START button. The switch is reset.

MPS Part Numbers

Amp Rating (Range)	Part Number
0.6 – 1.0	PRP232036-000
1.0 – 1.6	PRP232036-001
1.6 – 2.5	PRP232036-002
2.5 – 4.0	PRP232036-003
4.0 – 6.3	PRP232036-004
6.3 – 10.0	PRP232036-005
10.0 – 16.0	PRP232036-006

Note: The current draw on the MPS must be set to within 10% of the motor's FLA (Full Load Amp) rating. Failure to set the MPS properly can result in the premature failure of the motor.

Heating Element Replacement & Element Thermocouple Replacement

To replace the heating element or perform routine maintenance, follow these steps. The wattage and phase of the heating element are listed on the identification label on the outside of the element. Reference this label for the replacement element part number.

WARNING

BEFORE WIRING, SERVICING OR CLEANING THE SYSTEM, TURN OFF THE POWER AND INSTALL A LOCKOUT ON THE HEATER CIRCUITS AT THE SERVICE PANEL. FAILURE TO DO SO COULD ALLOW OTHERS TO TURN ON POWER UNEXPECTEDLY, WHICH MAY CAUSE FATAL ELECTRICAL SHOCK.

Step 1 Turn the heating system OFF and lock out at the service.

Step 2 Drain the fluid from the heating tank.

Step 3 Remove the cap from the heating element.

Step 4 The wire connections inside the cap of the heating element correspond to one of the phase configurations shown on the following page. Note your unit's phase configuration.

*Replacement elements can be a different phase configuration. Wire replacement elements to the cup washers on the replacement element studs.

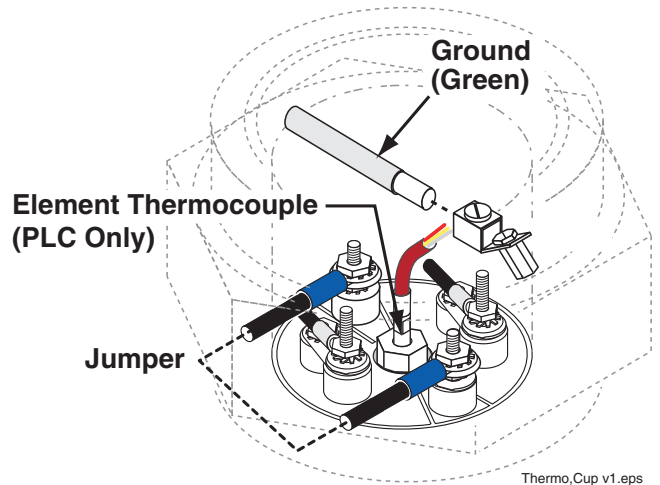

Remove the ground (green) and power electrical wires from the posts inside the cap.

Step 5 On PLC controlled systems, remove the thermocouple from the heating element burr after removing compression fitting nut. See Step 4 of Thermocouple Replacement.

Step 6 Remove the conduit conductor and electrical wires from the heating element.

Step 7 Remove the V-clamp to remove the heating element from the heating tank as shown on the next page.

Step 8 Replace the heating element or perform the necessary cleaning procedure. Ensure the O-ring is in place.

Re-assembly of Heating Element and Tank

To reassemble the heating element and tank, follow the steps listed on page 3-8 in reverse order. Make sure the ground and power electrical wires are properly reconnected using the washers, cup washers and nuts supplied (please note diagram at bottom of page). Replace Thermocouple using the old thermocouple and compression fitting or replace with a new one.

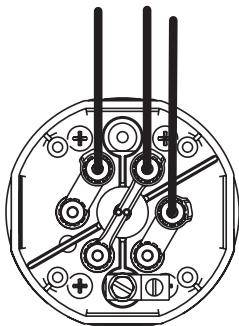
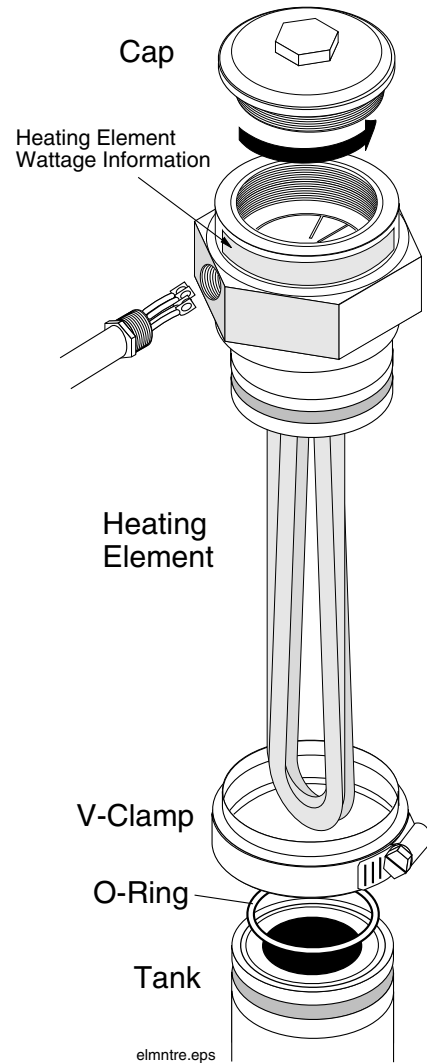

3 Phase Delta

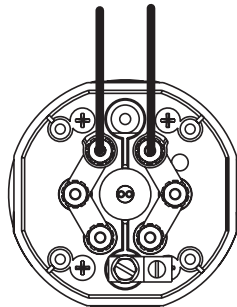

1 Phase Parallel

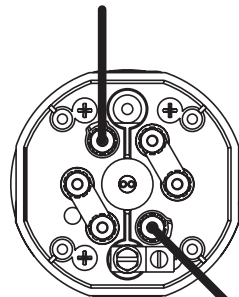

1 Phase Series

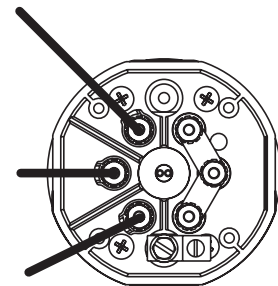

3 Phase Wye

PLC Controlled Systems

(Tank Thermocouple Replacement)

One of the system thermocouples is located inside the thermocouple housing at the end of each heating tank as shown below. To replace this thermocouple, follow the steps listed below.

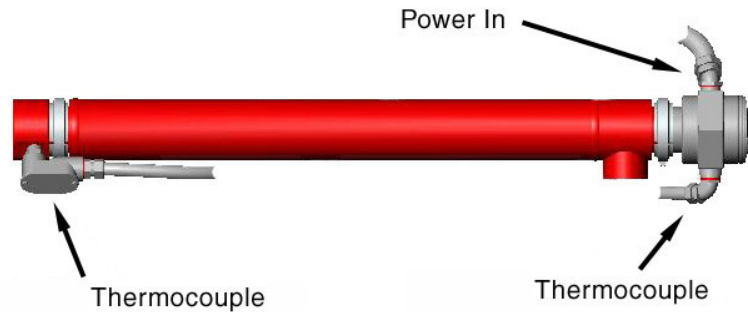

Thermocouple P/N: PRP224066-001
Compression fitting P/N: PRP218068-001

WARNING

BEFORE WIRING, SERVICING OR CLEANING THE SYSTEM, TURN OFF THE POWER AND INSTALL A LOCKOUT ON THE HEATER CIRCUITS AT THE SERVICE PANEL. FAILURE TO DO SO COULD ALLOW OTHERS TO TURN ON POWER UNEXPECTEDLY, WHICH MAY CAUSE FATAL ELECTRICAL SHOCK.

- Step 1** Remove the cover of the service entrance enclosure.
- Step 2** Disconnect the thermocouple wires in the control box at the thermocouple module.
- Step 3** Attach a string to the end of the thermocouple wires where they were removed from the thermocouple module. Then pull the wires and the string out of the conduit at the service entrance. The string will provide a way to pull the new thermocouple wires through the conduit back into the control box.
- Step 4** Loosen the nut on the compression fitting that is holding the thermocouple in place. The nut can be loosened using a deep offset box wrench or a deep socket. Run the end of the wires, removed at the thermocouple module, through the wrench or socket and slide it down onto the nut. If a socket is used, put Vise Grip Pliers on the top of the socket to turn it (the wires go through the drive hole).
- Step 5** Pull the thermocouple out of the compression fitting, if you plan to re-use the thermocouple, save the nut and compression fitting on the thermocouple. If not, replace the compression fitting as well as the thermocouple.

Reassemble in reverse order making sure that the wire end of the thermocouple extends 1/4 inch above the compression fitting.

PLC Control Troubleshooting

PLC (programmable logic controller) controlled heating systems indicate some of the most common errors, either on the text display, or with a flashing light on the control box lid. If more than one error exists at the same time, only the last error will show on the display. The three previous codes will be listed at the top right of the text display.

The following Code Numbers and Descriptions are provided to indicate the type of error:

ERROR CODE TABLE

Code	Description
1	Heating Element
2	Differential Temp/Lack of Flow
3	Low Temperature
4	Over Temperature
5	Thermocouple Open/Short
6	Motor Protective Switch Tripped
7	Thermocouple Range
8	Thermocouple Module/Power

Error is indicated when the Text Display reads out the error and the pilot light or PLC light flashes the above number of flashes followed by a three second pause. Repeats until repaired and system restarted.

PLC System Troubleshooting			
Code	Error Code Description	Possible Causes	Solutions
1	Heating Element	Heating element failure	Check element for continuity, replace if necessary.
		Element fuses failed	Check all element fuses for continuity and replace as necessary
		Heating element contactor failure	Check contacts and coil. Replace if needed
2	Differential Temp / Lack of Flow	Pump not primed properly	Bleed all trapped air from lines
		Isolation valves may be closed	Open valves
		Hose kinked or mashed	Remove obstruction
		Leak in suction line	Repair leak
		Pump motor turning backwards	Reverse any two leads on power in (3 phase systems)
		Motor protective switch tripped	Check and reset, if problem happens again check motor
3	Low Temperature	Heater has been turned off, fluid is cold	Allow time for heater to heat fluid. Error will clear automatically.
		Heating element failure	Check elements for continuity and replace if needed
		Contactor failure	Check contacts and coil. Replace if needed
		Blown fuse	Check fuse and replace if needed
		Could be a result of another error below:	Shut system down and restart watch for other errors. Only the last error will be displayed
		Motor protective switch tripped	Check and reset, if problem happens again check motor
		Motor contactor failure	Check contacts and coil replace if needed
		Motor failure	Check and replace if needed

PLC System Troubleshooting (cont.)			
Code	Error Code Description	Possible Causes	Solutions
4	Over Temperature	Thermocouple failure	Check Thermocouple and replace if necessary
		Motor contactor failure	Check contacts and coil replace if needed
		Motor failure	Check and replace if needed
		Could be a result of another error below	Shut system down; allow cooling to normal temp and restart. Original error should be displayed first before high temp error, if caused by another error.
		Pump not primed properly	Check for "Differential temp / lack of flow error", see above
		Isolation valves may be closed	Open isolation valves
		Hose kinked or mashed	Repair or replace
		Leak in suction line	Repair
		Pump motor turning backwards	Reverse any two leads on power in (3 phase systems)
5	Thermocouple Open / Short	Thermocouple failure	Check thermocouple and wiring replace if needed
6	Motor Protective Switch Tripped	Motor Protective Switch Tripped	Check and reset, if problem happens again check motor and wiring
		Cold oil	Motor overload, warm oil by other means, then restart
7	Thermocouple Range	Improper thermocouple used	Replace with original equipment parts only
8	Thermocouple Module / Power	Power to thermocouple module lost	Check wiring from PLC to thermocouple module
		Thermocouple module failed	Red lights on thermocouple module indicate a failure, check wiring, replace if needed

Mechanical System Troubleshooting		
Symptoms	Possible Causes	Solutions
Lack of Flow	Pump not primed properly	Bleed all trapped air from lines
	Isolation valves may be closed	Open valves
	Hose kinked or mashed	Remove obstruction
	Leak in suction line	Repair leak
	Pump motor turning backwards	Reverse any two leads on power in (3 phase systems)
	Motor protective switch tripped	Check and reset, if problem happens again check motor
Low Temperature	Heater has been turned off, fluid is cold	Allow time for heater to heat fluid
	Heating element failed	Check elements for continuity and replace if needed
	Element fuses failed	Check all element fuses for continuity and replace as necessary
	Element contactor failed	Check contacts and coil. Replace if needed
	Motor protective switch tripped	Check and reset, if problem happens again check motor
	Motor contactor failed	Check contacts and coil replace if needed
	Motor failed	Check and replace if needed
	Thermostat failed	Check and replace if needed
	Flow switch shut down	See lack of flow above
Over Temperature	Motor contactor failure	Check contacts and coil replace if needed
	Motor failure	Check and replace if needed
	Pump not primed properly	Check for "Differential temp / lack of flow error", see above
	Isolation valves may be closed	Open isolation valves
	Hose kinked or mashed	Repair or replace
	Leak in suction line	Repair
	Flow switch failed	Check and replace if needed
	Thermostat failed	Check and replace if needed
Motor Protective Switch Tripped	Motor or wiring short circuit	Check motor and wiring, replace if needed
	Cold oil	Motor overload, warm oil by other means, then restart