

HOTflow™ HEATING SYSTEM — CTM

HOTSTART's HOTflow™ heating system (CTM model) is a complete coolant preheater. It features an integrated pump that combines the benefits of forced circulation with a compact design that can mount to a variety of small engine applications. The CTM model heats engines up to 20L displacement. Forced circulation of the coolant delivers uniform heating throughout the entire engine, extends element life and offers a significant reduction in electrical consumption.



APPLICATION

HOTflow™ model CTM was developed to preheat diesel and gas engines for stationary land power, marine and construction equipment.

SPECIFICATIONS

- Heating Fluid: Engine coolant (50% glycol/50% water)
- Heat Power: 1, 1.5, and 2.5 kW
- Voltage Range: 1 Phase 120V, 60Hz, 240V 50/60Hz
- Fixed Thermostat: 100-120°F (38-49°C)
- Ingress Protection**: IP44
- Flow*: 2.5GPM (.57 m³/hr) @ 1PSI (7 kPa)
- Flow**: 2.5GPM (.57 m³/hr) @ 3 PSI (21 kPa)
- Inlet/Outlet: .625" (16mm) hose barb
- Cord connected with plug
- For use in weather protected applications

* - 120V models
** - 240V models

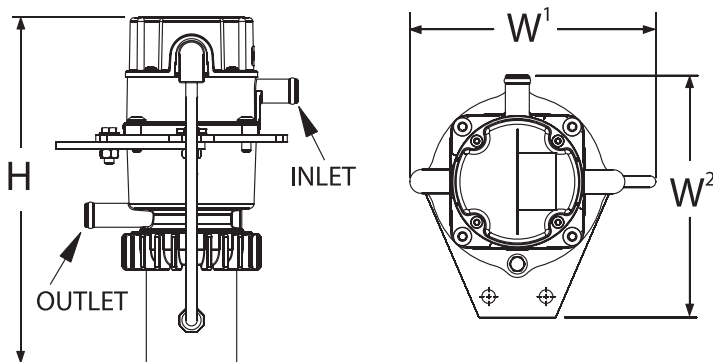

Dimensions & Weight

120V Models			
Height (H)	Width1 (W)	Width2 (W)	Weight
10.0" 254mm	6.4" 163mm	6.3" 160mm	3.5 lbs. 1.6 kg
240V Models			
Height (H)	Width1 (W)	Width2 (W)	Weight
9.0" 230mm	6.4" 163mm	6.3" 160mm	3.0 lbs. 1.3 kg

FEATURES

- UL C/US listed (E250789) models available
- CE compliant models available
- Compact design
- Easy to install
- Patent # - D626570



HOTflow™ HEATING SYSTEM — CTM



PART NUMBERS

Engine Displacement	120V	240V N. American power cord	240V Euro power cord	kW	Amps 120/240V	Thermostat Range
0 - 500cid 0 - 8L	CTM10110-A01	CTM10210-N00 CTM10210-A00	CTM10210-E00	1	8.8/4.4	On 100°F (38C) Off 120°F (49C)
500 - 750cid 8 - 12L	CTM15110-A01	CTM15210-N00 CTM15210-A00	CTM15210-E00	1.5	13.0/6.5	On 100°F (38C) Off 120°F (49C)
750 - 1200cid 12 - 20L	CTM25110-A01	CTM25210-N00 CTM25210-A00	CTM25210-E00	2.5	21.3/10.7	On 100°F (38C) Off 120°F (49C)

UL C/US Listed Models

Engine Displacement	120V	kW	Amps 120V	Thermostat Range	
				On	Off
0 - 500cid 0 - 8L	CTM10110-N01	1	8.8	100°F (38C)	120°F (49C)
500 - 750cid 8 - 12L	CTM15110-N01	1.5	13.0	100°F (38C)	120°F (49C)
750 - 1200cid 12 - 20L	CTM25110-N01	2.5	21.3	100°F (38C)	120°F (49C)

Suffix Descriptions

Suffix	Description	Industry Approvals
A00	3m cord, no plug Laing pump	
A01	3m cord, no plug Grundfos pump	
E00	Schuko plug Laing pump	CE compliant
N00	NEMA plug Laing pump	
N01	NEMA plug Grundfos pump	UL C/US listed

