

CGM Coolant Heating System

The HOTSTART CGM is a complete, packaged heating system with pump, PT-100 temperature sensors and all required controls. The CGM heats engines up to 1200L displacement. Forced circulation of the coolant delivers uniform heating throughout the entire engine, enhances availability, decreases wear and tear from cold starts and extends element life.

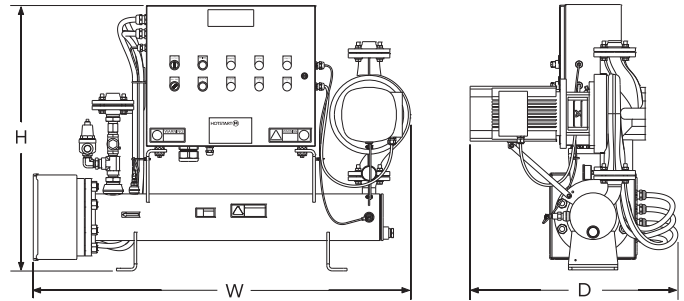

APPLICATION

The CGM was developed to pre-heat diesel and gas engines for stationary land power, marine, rail, large mining and construction equipment.

SPECIFICATIONS

- Heating Fluid: Engine coolant (50% glycol/50% water)
- Power: 90 - 144kW in 3 or 4 stages
- Rated Voltage: 400V 50Hz, 440-480V 60Hz, 660/690V 50/60Hz 3ph
- Temperature Controller: Adjustable 32°-212°F (0°-100°C)
- Temperature Setting: 140°F (60°C)
- High Limit Temperature Control: Adj. 32°-212°F (0°-100°C)
- High Limit Temperature Setting: 95°C
- Fluid Capacity: 5.0 gal (19.0L)
- Pump Power: 3Hp (2.2kW)
- Flow: 70GPM @ 70ft (16 m³/hr @ 21mWc)
- Max Pressure: 100 psi (690 kPa)
- Pressure Loss @ Rated Flow: 5 psi (35 kPa)
- Pressure Relief Valve Setting: 100 psi (690 kPa)
- Inlet Plumbing: DN40 flange w/counter flange
- Outlet Plumbing: DN40 flange w/counter flange
- Main Control Box Ingress Protection: IP66
- Motor Ingress Protection: IP55
- Ambient Temp. Rating: -4°- 104°F (-20° - 40°C)

FEATURES

- CE compliant
- Designed and tested to meet DNV Marine Classification
- 24VDC relay for auto ON/OFF
- Auxiliary contacts for remote monitoring

DIMENSIONS & WEIGHT

Height (H)	Width (W)	Depth (D)	Weight
37.7"	53.6"	29.5"	370 lbs.
958mm	1361mm	749mm	167 kg