

INSTALLATION INSTRUCTIONS

BATTERY HEATING PADS & WRAPS

BATTERY WRAPS

CAUTION

Electrical hazard: Disconnect battery before installation. Power source must be properly grounded and in accordance with national and local electrical codes. Do not connect wrap to power source prior to installation.

Personal injury: To avoid possible electrical or fire hazard, inspect plug and exposed cord for wear or damage prior to each use. Disconnect heater prior to performing service.

NOTICE

Overheating hazard: If battery is enclosed in an insulated battery case, a wrap with thermostat is recommended to prevent battery overheating. Excessive overlap or an obstructed thermostat may cause overheating. Overheating may damage battery or shorten battery life.

Battery damage: Battery wrap heaters are not recommended for nickel cadmium batteries.

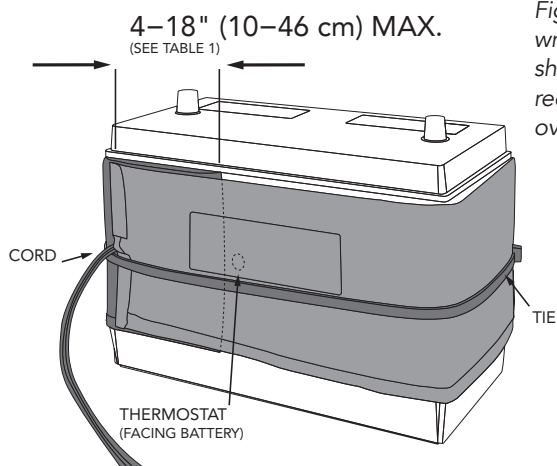

Figure 1. Battery wrap installation, showing maximum recommended overlap.

INSTALL WRAP

1. Disconnect battery negative terminal and then positive terminal. Remove battery.
2. Clean battery sides. If enclosed, clean battery case.
3. Wrap battery. Ensure thermostat is facing battery.

NOTE: Do not exceed the recommended maximum overlap length. See Table 1.

WATTS	MAX. OVERLAP
50	4 inches (10 cm)
80	6 inches (15 cm)
100	18 inches (46 cm)

4. Secure wrap to battery with supplied tie. Remove excess tie.
5. Route and secure cord. Ensure battery does not rest on cord. Do not secure cord to hot surfaces or moving parts.
6. Reconnect battery. Connect positive terminal first, then connect negative terminal. Connect wrap to appropriately rated power source.
7. Check wrap and electrical connections for wear or excessive heat every two years of operation.

**Corporate & Manufacturing
Headquarters**
5723 E. Alki Ave
Spokane, WA 99212 USA
509.536.8660
sales@hotstart.com

Oil & Gas Office
21732 Provincial Blvd.
Suite 170
Katy, TX 77450 USA
281.600.3700
oil.gas@hotstart.com

Europe Office
HOTSTART GmbH
Am Turm 86
53721 Seigburg, Germany
+49.2241.12734.0
europe@hotstart.com

Asia Pacific Office
HOTSTART Asia Pacific Ltd.
2-27-15-4F Honkomagome
Bunkyo-ku, Tokyo
113-0021, Japan
+81.3.6902.0551
apac@hotstart.com

BATTERY PADS

CAUTION

Electrical hazard: Disconnect battery before installation. Power source must be properly grounded and in accordance with national and local electrical codes. Do not connect pad to power source prior to installation.

Personal injury: To avoid possible electrical or fire hazard, inspect plug and exposed cord for wear or damage prior to each use. Disconnect heater prior to performing service.

NOTICE

Overheating hazard: If battery is enclosed in an insulated battery case, a thermostat is recommended to prevent battery overheating. Overheating may damage battery or shorten battery life.

Battery damage: Pad heaters are not recommended for nickel cadmium batteries.

HOTSTART recommends installing the pad on a flat, uniform surface. Ensure both the surface the pad will be installed on and the battery bottom surface are clean before installing heating pad.

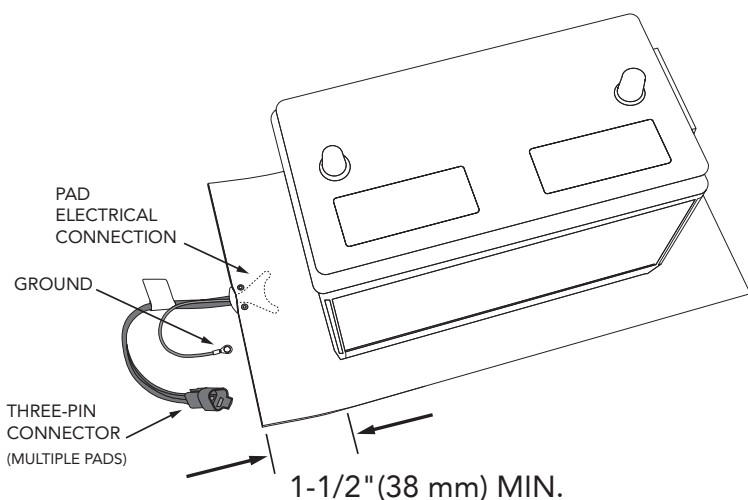

Figure 2. Battery pad installation, showing minimum 1-1/2 inch (38 mm) clearance between battery and pad edge.

INSTALL PAD

1. Disconnect battery negative terminal and then positive terminal. Remove battery or batteries.
2. Clean bottom of battery and floor of battery case or intended pad surface.

3. Place pad on surface or in enclosure with writing side facing upward.
4. Connect battery pads.
 - If installing a single battery pad, connect ground wire.
 - If installing multiple battery pads, connect pads using three-pin connectors. Ensure connections are secure and latch is engaged. Connect ground wire. See Fig 3.

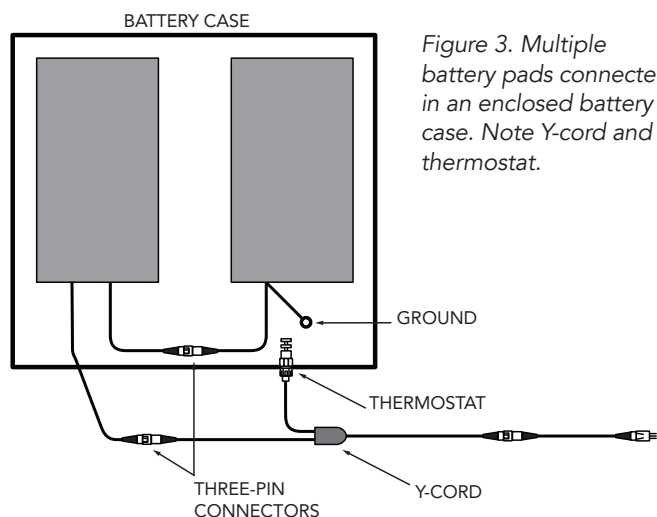

Figure 3. Multiple battery pads connected in an enclosed battery case. Note Y-cord and thermostat.

5. Route and secure cords to ensure that batteries do not rest on cords. Do not secure cords to hot surfaces or moving parts.
6. Place battery on pad. Ensure that battery is placed a minimum of 1-1/2 inches (38 mm) away from edge of pad to prevent damage to pad electrical connection. See Fig. 2.
7. Reconnect battery or batteries. Connect positive terminal first, then connect negative terminal. Connect pad to appropriately rated power source.
8. Check pad and electrical connections for wear or excessive heat every two years of operation.