

# INSTALLATION INSTRUCTIONS

## THERMOSIPHON HEATER VH MODEL

Hotstart Manufacturing, Inc. is the owner of all trademarks and copyrightable material contained herein; all rights are reserved; no form of reproduction is authorized without prior written consent from Hotstart Manufacturing, Inc.

### BEFORE YOU INSTALL

Your VH heater uses thermosiphon action – *the natural expansion and rising action of a heated fluid* – to circulate heated coolant throughout an engine’s water jacket. With no moving parts, thermosiphon heaters require little maintenance. However, initial installation of the heating system is critical; even seemingly minor adjustments to port location, hose routing or heater positioning may help ensure your thermosiphon heater preheats your engine effectively.

#### ⚠ CAUTION

**Hazardous voltage:** Before wiring, servicing or cleaning the heating system, turn off the power and follow your organization’s lockout and tagout procedure. Failure to do so could allow others to turn on the power unexpectedly, resulting in harmful or fatal electrical shock.

**Electrical hazard:** Power source must be properly grounded and in accordance with national and local electrical codes. Do not connect heater to a power source heater prior to installation.

**Personal injury:** If equipped with isolation valves, ensure valves are open before energizing heater. Obstructed flow may result in an unexpected release of heated coolant, potentially causing serious injury.

#### NOTICE

**Read instructions carefully:** The Hotstart warranty does not cover any damage that a heating system may sustain from improper installation, improper operation, improper specification or corrosion. Before installing your heater, be sure you have the right heating system for your application. Carefully read all instructions before installing and energizing your heater.

**Proper operation:** The Hotstart heating system is intended to be activated only while the engine is not in operation. Preheating while the engine is running may reduce heater longevity. For automatic-start engines, a control box with automatic shut-off device is recommended.

Figure 1. Typical VH model. Style and configuration may vary.

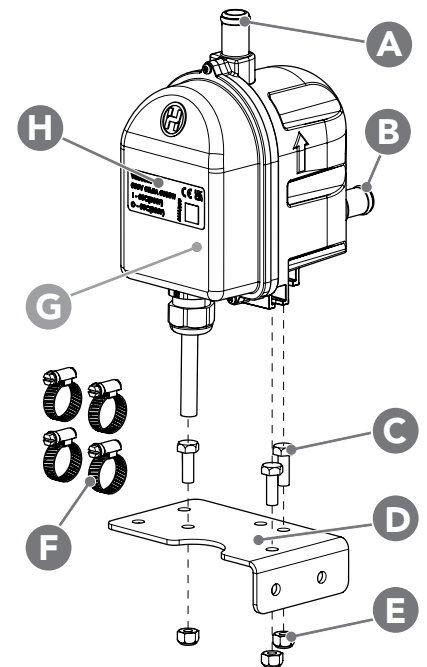

- |    |                  |    |                                  |
|----|------------------|----|----------------------------------|
| A. | Outlet           | F. | Hose clamps × 4                  |
| B. | Inlet            | G. | Control thermostat (in assembly) |
| C. | Bolt × 3         | H. | ID label                         |
| D. | Mounting bracket |    |                                  |
| E. | Nut × 3          |    |                                  |

Corporate & Manufacturing Headquarters  
 Spokane, WA, USA

509.536.8660  
[sales@hotstart.com](mailto:sales@hotstart.com)

Hazardous Location/ Marine Office  
 Katy, TX, USA

281.600.3700  
[hazloc@hotstart.com](mailto:hazloc@hotstart.com)  
[marine@hotstart.com](mailto:marine@hotstart.com)

Railroad Office  
 Merrillville, IN, USA

219.648.2448  
[railroad@hotstart.com](mailto:railroad@hotstart.com)

Europe Office  
 Koln, Germany

+49.2203.98137.30  
[europe@hotstart.com](mailto:europe@hotstart.com)

United Kingdom Office  
 Birmingham, UK

+44.0121.809.5468  
[UK@hotstart.com](mailto:UK@hotstart.com)

Asia Pacific Office  
 Tokyo, Japan

+81.3.6902.0551  
[apac@hotstart.com](mailto:apac@hotstart.com)

# INSTALLING THE HEATER

## PREPARE COOLANT SYSTEM

1. Drain and flush cooling system to remove any debris present in the engine's cooling system.

## SELECT PORTS

2. Select return port. The return port will allow heated coolant to return to the engine. See Fig 2 on following page. Select the return port using the following guidelines:

- return port must be located on the same side of the engine as the intended heater mounting location
- return port must be located away from the engine thermostat
- return port should be located toward the rear (flywheel) of the engine
- return port should be located away from the supply port

3. Select supply port. The supply port will allow coolant to flow from the engine to the heater. See Fig 2 on following page. Select the supply port using the following guidelines:

- Supply port may be located on the same side or opposite side of the engine as the intended heater location

**NOTE:** For V-type engines, it is acceptable to select a supply port on the opposite side of the engine as long as the supply hose is routed properly. See **PLUMB HEATER**.

- Supply port must be located at the lowest point of the engine's water jacket
- Supply port should be located toward the front (radiator) of the engine
- Supply port should be located away from the return port

## SELECT HOSE, FITTINGS & VALVES

4. Select fittings. VH minimum port size fitting:

- 3/8 inch NPT (9.5 mm)

5. Select hoses. Use the following table to determine the minimum hose inner diameter for your heater:

VH	1000 watts	➔	5/8 inch (16 mm)
	1500 watts	➔	3/4 inch (19 mm)
	2550 watts	➔	3/4 inch (19 mm)

**NOTE:** Select hoses rated for 250 °F (121 °C) and 100 psi (690 kPa) minimum.

6. Select optional, user-supplied isolation valves.

**NOTE:** Hotstart recommends installing valves to isolate the heating system in case of service. To minimize flow restriction, select full-flow (full-port) ball isolation valves.

# MOUNT HEATER

## NOTICE

**Vibration damage:** Do not mount heater directly to engine. Engine vibration may damage heater. If the heater is installed with rigid pipe, connect flexible hose to inlet and outlet to isolate from vibration.

**Outlet orientation:** Ensure outlet is at top of heater. Do not attempt to mount heater at an angle or in any other orientation. An incorrectly oriented outlet may cause heater failure.

7. Select a heater mounting position directly below the return port and at least 6 inches (15 cm) below the lowest point of the engine's water jacket.

8. Using supplied mounting bracket, nuts, and bolts, mount heater to suitable vibration-isolated surface.

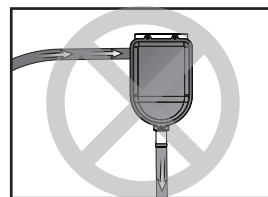
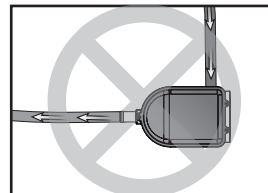

## PLUMB HEATER

## NOTICE

**High points:** Do not allow high points along heater plumbing. High points will restrict coolant flow and damage heater. To avoid high points, it may be necessary to change hose routing or lower heater mounting location.

**Dips and bends:** Do not allow dips or bends along heater plumbing. Dips or bends will allow air pockets to form, restricting coolant flow and damaging heater.

**90° Fittings:** Elbows (90° fittings) along heater plumbing may restrict flow and damage heater. To minimize flow restriction, Hotstart recommends sweeping bends or 45° fittings in place of 90° fittings.

9. Install isolation valves to port fittings.

10. Route and install return hose. **NOTICE!** The return hose must continuously rise from the heater to the return port.

11. Route and install supply hose. **NOTICE!** The supply hose must continuously descend from the supply port to the heater.

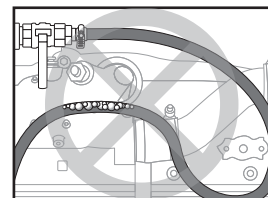
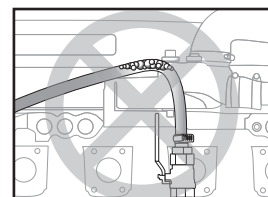
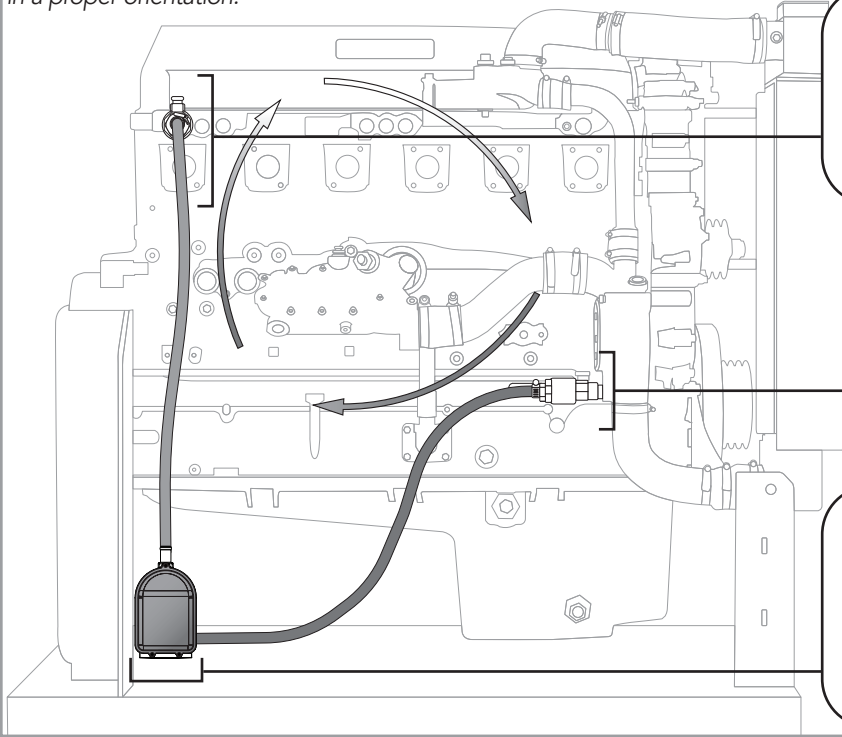

Figure 2. Example VH installation. The return hose continuously rises to the engine and supply hose continuously descends to the heater; the hoses have no dips, bends or high points. The heater is isolated from engine vibration and is mounted in a proper orientation.



## RETURN PORT

- Select a **return** port away from the engine thermostat.
- Select a **return** port toward the rear of the engine.
- Select a **return** port away from the **supply** port.

## SUPPLY PORT

- Select a **supply** port low on the engine.
- Select a **supply** port toward the front of the engine.
- Select a **supply** port away from the **return** port.

## HEATER MOUNTING

- Mount the heater in the proper orientation. Ensure outlet is pointing directly upward.
- Mount the heater to a vibration-isolated surface.
- Mount the heater on the same side as the **return** port.

12. If installed, open supply port isolation valve and return port isolation valve. **WARNING!** Operation of a heating system with closed isolation valves could result in high pressure and serious injury.

14. Start engine. Allow engine to run until engine thermostat opens, purging air from engine cooling system. **NOTICE!** Engine must be run to eliminate air from heating system before energizing heater.

15. When engine has reached operating temperature, shut engine off and check for coolant leaks. Allow engine to cool. Check coolant level and top off as needed.

## REFILL COOLANT

### NOTICE

**Heater damage:** When mixing coolant, only use deionized or distilled water and low-silicate antifreeze. Refer to your engine's manufacturer recommendations. Do not exceed 60% antifreeze to 40% water ratio. **Never** add unmixed water and antifreeze to an engine. Do not add anti-leak or other coolant additives.

13. Mix coolant according to your engine manufacturer's recommendations. Refill cooling system with coolant.

**NOTE:** Hotstart recommends using a 50% deionized or distilled water to 50% low-silicate antifreeze mixture.

Figure 3. When refilling engine with coolant, remove heater return hose (A). Once filled to level of return port, reconnect return hose to ensure no air remains in heating system (B).

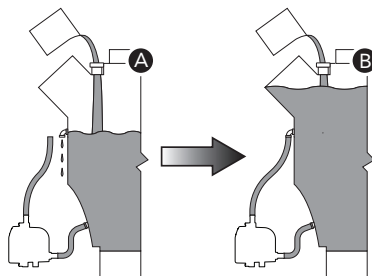

## CONNECT HEATER

16. Connect heater to an appropriately rated power source. Ensure power source is grounded and in accordance with local and national electrical codes.

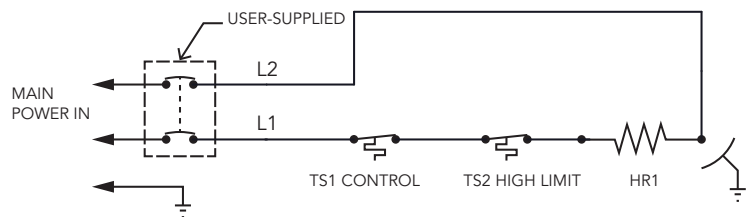

Figure 4. Typical VH wiring schematic

# TROUBLESHOOTING

To ensure coolant is flowing, check the outlet temperature. If the coolant temperature along the return hose exceeds 180 °F (82 °C) or the heater cycles more than four times per hour, it may indicate:

- Air pockets are restricting flow. Air may collect due to loops in hose, routing hose over the top of the engine, excessive hose lengths, or kinks. Reroute hoses or change port locations.
- Heater is mounted too high. Lower heater position.
- Heater is not mounted in the proper orientation. Ensure outlet is pointed directly upward.
- Contaminants in the coolant are restricting flow. Flush coolant system and refill.

# MAINTENANCE & PARTS

## ⚠ CAUTION

**Electrical hazard:** Before wiring, servicing or cleaning the heating system, turn off the power and follow your organization's lockout and tagout procedure. Failure to do so could allow others to turn on the power unexpectedly, resulting in harmful or fatal electrical shock.

**Personal injury:** If equipped with isolation valves, ensure valves are open before energizing heater. Obstructed flow may result in an unexpected release of heated coolant, potentially causing serious injury.

## PREVENTATIVE MAINTENANCE

Annually:

- Check and replace cracked or weakened hoses.
- Check electrical wiring for wear and excessive heat

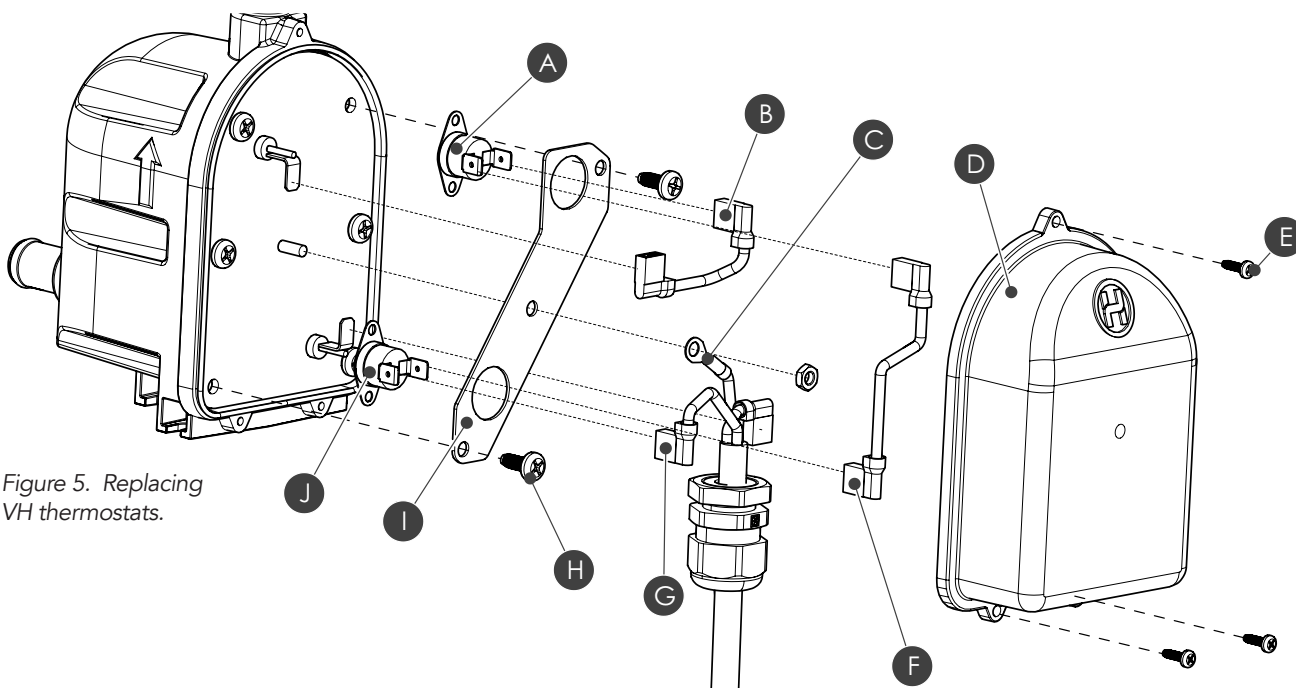

Figure 5. Replacing VH thermostats.

Every three years or 25,000 hours of operation:

- Replace control thermostat sensing unit.

# THERMOSTAT REPLACEMENT

To replace the control thermostat: (See Fig. 5.)

1. Disconnect heater from power source. Allow heating system to cool.
2. Unscrew and remove enclosure screws ×3 (E). Pull enclosure (D) away from heater. Set screws aside. Note wiring connections.
3. Disconnect power connection (G) to control thermostat (J). Disconnect ground (C).
4. Disconnect thermostat jumper wire (F). Disconnect high limit thermostat connection to element (B).
5. Unscrew thermostat clip screws ×2 (H) and remove thermostat clip (I). Set screws aside.
6. Insert replacement control thermostat (J) or high limit thermostat (A).
7. Place clip (I) over thermostats and secure in place using thermostat clip screws (H).
8. Reconnect thermostat jumper wire (F) to thermostats. Reconnect high limit thermostat connection to element (B).
9. Reconnect power connection (G) to control thermostat (J). Reconnect ground (C).
10. Place enclosure (D) on heater. Tighten enclosure screws (E) to secure. **NOTICE!** Do not overtighten enclosure screws.
11. Reconnect heater to power source.