



Customer Support: (509) 536-8660
E-Mail: sales@hotstart.com

Installation Instructions

HOTflow™ CTM Heating System

READ CAREFULLY FOR PROPER INSTALLATION AND OPERATION

ADDITIONAL SUPPORT CAN BE FOUND AT WWW.HOTSTART.COM

The CTM forced circulation heater combines a pump, heating elements, and temperature control system. It is created to heat engine coolant that consists of 50/50 glycol and water mixture. The heater is designed to provide heating for engine displacements up to 20L in size. The forced circulation of the coolant provides uniform heating throughout the engine. The heater is used to heat diesel and gas engines for stationary land power, marine, large mining, and construction equipment. The heater is rated for 240V power supply with power output of 1000W, 1500W, and 2500W. The minimum ingress protection rating is IP44. The heater is rated for the conditions listed in EN 601010-1:2010 1.4.1. Special configurations per customer specification also apply.

NOTICE

Please read carefully: The safety of any system incorporating this heater is the responsibility of the assembler. The safe and proper use of this heater is dependent upon the installer following sound engineering practices. If the equipment is used in a manner not specified by the manufacturer, the protection provided by the equipment may be impaired. All work to be performed by qualified personnel only. Heater must be connected to a suitable protective earthing conductor. The power supply to be protected by a suitable overcurrent limiting device. A means of disconnection from power supply is required. Hotstart recommends that a power switch or circuit-breaker be located near the heater for safety and ease of use. Reference markings on the heater for specific ratings.

CAUTION

Personal Injury: PED (97/23/EC) compliant pressure relief is required in the EU. This product generates heat during operation. It is intended to be incorporated into a system containing fluid. It is the responsibility of the assembler to ensure that no unsafe condition can result from the generation of pressure.

CAUTION

Personal Injury: Hot surfaces are a potential injury hazard. It is the responsibility of the assembler to ensure that hot surfaces are not easily accessible to untrained personnel during operation.

CAUTION

Heater Damage: Do not connect unit to electricity until the following steps have been completed. Never operate heater in air. Verify heater is full of coolant and properly plumbed.

NOTICE

Heater Control: If heater is configured for continuous pump operation; automatic disconnect is required during engine operation. See Figure 6. Customer supplied disconnect not shown.

INSTALLATION RECOMMENDATIONS

1. Drain and thoroughly flush cooling system.
2. Mount heater as shown in figure 1 with the pump at the bottom and the power cord connection at the top. Attach the heater as low as possible to the equipment frame or other suitable area. Heater should be below the lowest level of the engine water jacket. The heater inlet must be below the point where coolant is removed from the engine.

NOTICE

The heater will operate correctly only if mounted in the vertical orientation as shown in Figure 1.

NOTICE

Vibration Damage: The heater must be isolated from engine vibration. Do not mount the heater directly to the engine or any components directly connected to the engine.

3. Install 5/8" (15 or 16 mm) heater hose between the heater inlet (suction) and the engine.

NOTICE

The inlet hose must route continuously downward from the engine to the heater with no dips or humps that can trap air. The coolant draw must be as close to directly above the heater as possible. See Figures 1. This will enhance air evacuation from the heater at start up and will insure the heater has a supply of coolant at all times.

4. Install 5/8" (15 or 16 mm) heater hose between the heater outlet (discharge) and the engine block. Locate the discharge port as far as possible from the suction port to enhance heat distribution throughout the engine.
5. Secure cord at intervals with tape or wire ties to avoid contact with all hot or moving parts.
6. Fill cooling system following the engine manufacturer recommendation for coolant.

WARNING

This product has been tested using water and all concentrations of glycol mixed with water up to 60% glycol. See engine manufacturer recommendation for coolant. The suitability of this product for use with other liquids is the responsibility of the end user.

7. Start and run engine until the engine reaches operating temperature. Shut off engine. Check for leaks. Re-tighten hose clamps where necessary. Let engine cool. Check coolant level, add if necessary.
8. Connect the heater to electrical power.

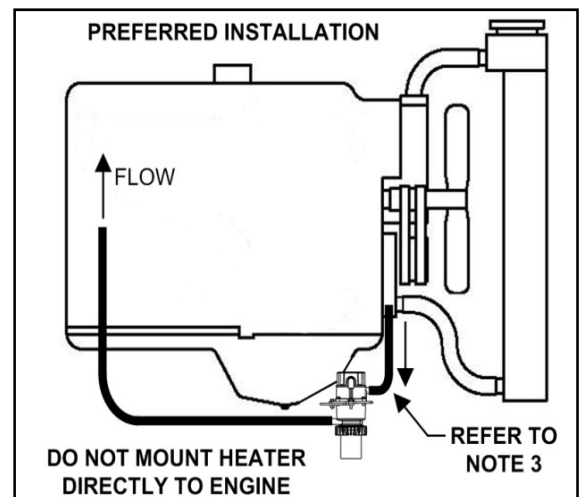

Figure 1

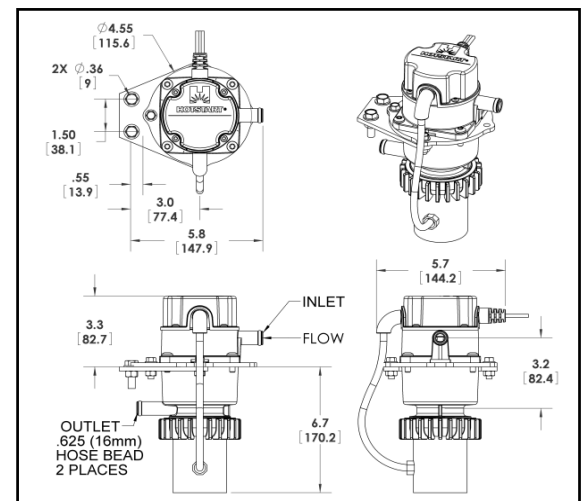

Figure 2

- Check heater for proper operation at regular intervals (up to an hour) by feeling the hoses. The temperature of the engine should warm up uniformly with just a few degrees difference between heater inlet and outlet. If one of the hoses becomes warm before the entire system, the coolant may not be circulating properly.

HEATER SERVICE:

WARNING Risk of Electric Shock - Disconnect electrical supply before removing cover – Service to be performed by qualified personnel only.

- If replacing/reorienting element assembly or replacing the pump - drain the cooling system or close the isolation valves. Steps 2 and 3 not needed for re-orienting ports.
- Remove the four screws holding the electrical cover in place as shown in Figure 5.
- While holding the two strain reliefs in place, remove the top electrical cover.
- Replace components:
 - Thermostat Replacement:** Remove the quick disconnects from the existing thermostat, element and ground connections. Remove cords from the slots in the base assembly.
 - Remove screw from the thermostat retainer. See Figures 3 and 4. Install new thermostat in reverse order.
 - Replace Element Assembly * Or Re-Orient ports **:**
 - * Remove quick-disconnects and ground terminals from existing thermostat, element and ground connections. Remove cords from the slots in the base assembly.
 - Remove the four screws holding the tank body.
 - * Replace element assembly with new unit.
 - ** Loosen pump nut. Orient inlet and outlet ports to the desired locations (90° increments). Hand-tighten the pump nut.
 - Reseat tank body o-ring in groove.

WARNING O-ring Damage: Ensure the o-ring is properly seated in the groove to prevent leakage from the heater. See Figure 5.

- Re-torque screws to 75 in-lbs (8.5 N-m), using a diagonal pattern. See Figure 3
- Note: The replacement element assembly includes a new element and new thermostat installed in a new base. A new o-ring and new enclosure gasket are also included.
- Re-attach electrical connections and cords in the reverse order. Torque the ground connection nuts to 23 in-lbs (2.6 N-m).
- Replace Pump:** Remove the pump cord connections and lift the pump cord out of the slot in the heater body. Unscrew the pump nut and install the new pump with the included o-ring and gasket. Hand-tighten the pump nut. Re-install the cord and connectors in reverse order. Torque the ground connection nut to 23 in-lbs (2.6 N-m).

- Replace the cover; torque the screws to 25 in-lbs (2.8 N-m) in a diagonal pattern.

WARNING Cover Gasket Damage: Ensure the gasket is properly aligned on the base before re-installing cover. See Figure 3.

- Re-fill the cooling system and purge air from the system per **INSTALLATION RECOMMENDATIONS** step 7.
- Re-connect the heater to electrical power. Verify proper heater operation per **INSTALLATION RECOMMENDATIONS** step 9.

